

Data Sheet

(規格書)

產品名稱 (Product)	<u>BLE AT Command Module</u> <u>in Peripheral / Slave role</u>
解決方案 (Solution)	<u>Nordic nRF54L15 QFN Package</u>
產品型號 (Model No.)	<u>AN54LQ – AT (Chip Antenna)</u>
韌體版本 (FW Rev.)	<u>1.0</u>

Advantage of AN54LQ series:

- 1. Long working distance:
AN54LQ: over 300 meters in open space.*
- 2. Declaration ID includes all Nordic applied profiles.*
- 3. Granted main regional certification such as FCC (USA), TELEC (Japan), NCC (Taiwan), CE(EU) , IC (Canada), SRRC (China), KC (South Korea) and WPC(India).*

Index

1. Overall introduction	5
2. AT Command	5
2.1. List of supported commands	5
2.2. AT Command sets	6
2.3. “Write” Commands	6
2.4. “Read” Commands	9
2.5. Response (Default)	10
2.6. Default Info	12
2.7. Pin Assignment	13
3. How to Control via External MCU	18
3.1. How to Send AT Commands	18
3.2. How to return to setting of default flash	19
3.3. How to Return to Flashed Default Setting	19
4. Test Report	20
4.1. Current Test	20
4.2. Throughput Test	21
5. Product dimension	23
5.1. PCB dimensions & Pin indication	23
5.2. Recommended layout of solder pad	24
5.3. RF layout suggestion (aka Keep-Out Area)	26
5.4. Footprint & design guide	27
6. Main chip solution	28
7. Shipment packaging information	29
7.1. Marking on metal shield	30
7.2. Packaging Info	31
7.2.1. Tray Packaging	31
7.2.2. Reel packaging	33
7.3. Order code	34
8. Specification	35
8.1. Recommended operating conditions	35
8.2. Radio specifications	35
8.2.1. General radio characteristics	35
8.2.2. Radio current consumption (Transmitter)	36
8.2.3. Radio current consumption (Receiver)	36

8.2.4.	Transmitter specification	36
8.2.5.	Receiver operation.....	37
8.2.6.	RX selectivity	37
8.2.7.	RX intermodulation	39
8.2.8.	Radio timing parameters.....	40
8.2.9.	RSSI specifications.....	40
8.3.	GPIO electrical specification.....	41
8.4.	Absolute maximum ratings	42
9.	Antenna.....	43
10.	Reference circuit	44
11.	Certification	45
11.1.	Declaration ID for Bluetooth.....	45
11.2.	FCC Certificate (USA)	46
11.3.	TELEC Certificate (Japan).....	49
11.4.	NCC Certificate (Taiwan)	50
11.5.	CE Test Report (EU).....	51
11.6.	IC Certificate (Canada).....	59
11.7.	SRRC Certificate (China).....	60
11.8.	KC Certificate	61
11.9.	WPC Certificate (India).....	62
11.10.	EU and UKCA Declarations of Conformity.....	64
11.11.	RoHS & REACH Report	64
11.12.	End-Product Label.....	64
11.12.1.	FCC (USA).....	65
11.12.2.	TELEC (Japan).....	65
11.12.3.	NCC (Taiwan).....	65
11.12.4.	IC (Canada)	66
11.13.	Compliance and Certification.....	67
11.13.1.	List of Applicable FCC Rules	67
11.13.2.	RF Exposure Considerations	67
11.13.3.	Antennas.....	68
11.13.4.	Information on Test Modes and Additional Testing Requirements.....	68
11.13.5.	Additional Testing, Part 15 Subpart B Disclaimer	69
11.13.6.	Note EMI Considerations	69
11.13.7.	How to Make Changes.....	69
12.	Notes and Cautions.....	70
13.	Useful Links	71

History of Firmware Revision..... 72

Release Note..... 79



1. Overall introduction

Raytac's AN54LQ - AT is a BT 6.0 stack (Bluetooth low energy or BLE) module designed based on **Nordic nRF54L15 SoC solution**, which incorporates: **UART** interface in only peripheral/slave role for data bridge in compact size **(L) 13.7 x (W) 9.5 x (H) 1.80 mm**.

2. AT Command

2.1. List of supported commands

- Setting of device name
- Choose data rate of 1Mbps or 2Mbps on-air
- Set TX output power in 6 levels.
- Set advertising time
- Set connection interval under Mode 2
- Enable/disable advertising
- 8 sets of UART baud rates
- Enable/disable UART flow control
- Enable/disable interface of UART hardware
- Power-down mode for power saving and GPIO wake-up
- Recover-to-default setting with hardware and software method
- System reset of hardware and software
- Set serial number and retrieve
- Set or retrieve MAC Address
- Retrieve ADC value for battery detection, delivering the information through battery service.
- Enable/disable connection command mode
- Setting of advertising interval
- Retrieve RSSI value of the connected

2.2. AT Command sets

2.3. “Write” Commands

No.	Command	Description
(1)	AT+NAME	Set device name. Max. length of 20 characters e.g. AT+NAME123 (device name 123, 3 characters)
(2)	AT+RESET	Set to reset system
(3)	AT+ADVSTART	Set to start advertising
(4)	AT+ADVSTOP	Set to stop advertising
(5)	AT+SLEEP	Set to get into deep sleep mode
(6)	AT+BAUDRATE9600	Set UART baud rate at 9600 bps,n,8,1
(7)	AT+BAUDRATE19200	Set UART baud rate at 19200 bps,n,8,1
(8)	AT+BAUDRATE38400	Set UART baud rate at 38400 bps,n,8,1
(9)	AT+BAUDRATE57600	Set UART baud rate at 57600 bps,n,8,1
(10)	AT+BAUDRATE115200	Set UART baud rate at 115200 bps,n,8,1
(11)	AT+BAUDRATE230400	Set UART baud rate at 230400 bps,n,8,1 (recommended enabling flow control)
(12)	AT+BAUDRATE460800	Set UART baud rate at 460800 bps,n,8,1 (recommended enabling flow control)
(13)	AT+BAUDRATE921600	Set UART baud rate at 921600 bps,n,8,1 (recommended enabling flow control)
(14)	AT+FLOWCONTROLDIS	Disable UART flow control
(15)	AT+FLOWCONTROLEN	Enable UART flow control
(16)	AT+TXPOWER7DBM	Set RF TX power at 7dBm
(17)	AT+TXPOWER4DBM	Set RF TX power at 4dBm
(18)	AT+TXPOWER0DBM	Set RF TX power at 0dBm
(19)	AT+TXPOWER-4DBM	Set RF TX power to - 4dBm
(20)	AT+TXPOWER-8DBM	Set RF TX power to - 8dBm
(21)	AT+TXPOWER-22DBM	Set RF TX power to - 22dBm
(22)	AT+CONNECTINDICATORLOW	Set logic low output when connecting BT
(23)	AT+CONNECTINDICATORHIGH	Set logic high output when connecting BT

No.	Command	Description
(24)	AT+PHYMODE1MBPS	Set PHY mode at 1Mbps
(25)	AT+PHYMODE2MBPS	Set PHY mode at 2Mbps
(26)	AT+WAKEUPLOW	Set logic low at wake-up when in deep sleep
(27)	AT+WAKEUPHIGH	Set logic high at wake-up when in deep sleep
(28)	AT+ADVTIMEtttt	Set advertising time (Hex format only; ASCII doesn't work), e.g. 0x001E (min. 30secs), 0x0258 (Max. 600secs) 0x0000 (forever)
(29)	AT+CONNECTINTERVALMODE0	Set connection interval mode for iOS/Android APP usage (min. 20ms / Max. 40ms),
(30)	AT+CONNECTINTERVALMODE1	Set connection interval mode for nRF52832 Central usage (min. 8ms / Max. 8ms)
(31)	AT+CONNECTINTERVALMODE2	Set connection interval mode for iOS/Android APP usage (programmable : min. / Max. range is 8ms ~ 1,000ms)
(32)	AT+CONNECTINTERVALTIMEtttttttt	Set connection interval time (Hex format only; ASCII doesn't work), available when activating "AT+CONNECTINTERVALMODE2" e.g. 0x0008 (8ms), 0x03E8 (1,000ms), conditions to be met: "min. connection interval ≤ Max. connection interval"
(33)	AT+COMMANDDIS	Disable command mode when connecting BT
(34)	AT+COMMANDEN	Enable command mode when connecting BT
(35)	AT+SERIALNOnnnnnnnn	Set serial number e.g. AB000001, fixed 8-character length
(36)	AT+RESPONSEDIS	Disable response when sending "write" command
(37)	AT+RESPONSEEN	Enable response when sending "write" command
(38)	AT+DISCONNECT	Terminate the connection, and the device will stop advertising. To restart the device, must send AT+ADVSTART
(39)	AT+DEFAULT	Back to default

2.4. “Read” Commands

No.	Command	Description
(1)	AT?NAME	To retrieve device name
(2)	AT?VERSION	To retrieve firmware version
(3)	AT?MACADDR	To retrieve IC MAC address
(4)	AT?BAUDRATE	To retrieve current UART baud rate
(5)	AT?FLOWCONTROL	To retrieve UART status of flow control
(6)	AT?TXPOWER	To retrieve RF TX power
(7)	AT?CONNECTINDICATOR	To retrieve logic of pin for BT-connecting indicator
(8)	AT?PHYMODE	To retrieve status of PHY mode
(9)	AT?WAKEUP	To retrieve logic of wake-up pin
(10)	AT?ADVTIME	To retrieve advertising time (Hex)
(11)	AT?CONNECTINTERVALMODE	To retrieve status of connection interval mode
(12)	AT?SERIALNO	To retrieve serial number
(13)	AT?ADCVALUE	To retrieve 14bit ADC value
(14)	AT?RESPONSE	To retrieve status of response
(15)	AT?CONNECTINTERVALTIME	To retrieve value of connection interval time under Mode 2
(16)	AT?BASEUUID	To retrieve base UUID value (Hex)
(17)	AT?SERVICEUUID	To retrieve service UUID value (Hex)
(18)	AT?TXCHARACTERUUID	To retrieve TX character UUID value (Hex)
(19)	AT?RXCHARACTERUUID	To retrieve RX character UUID value (Hex)
(20)	AT?ADVINTERVALTIME	To retrieve advertising interval time setting
(21)	AT?CONNECTRSSI	To retrieve RSSI value when in BLE connection (Ascii)

2.5. Response (Default)

No.	Command	Response
(1)	AT?NAME	Raytac AT-UART (default)
(2)	AT?VERSION	e.g. version: 1.0
(3)	AT?MACADDR	e.g. D352BDE1E414
(4)	AT?BAUDRATE	4 baudrate115200 (default) (0 = 9600; 1 = 19200; 2 = 38400; 3 = 57600; 4 = 115200; 5 = 230400; 6 = 460800; 7= 921600)
(5)	AT?FLOWCONTROL	0 flowcontrol dis (default) (0 = disabled; 1 = enabled)
(6)	AT?TXPOWER	0 txpower 7dbm (default) (0 = 7dBm; 1 = 4dBm; 2 = 0dBm; 3 = -4dBm; 4 = -8dBm; 5 = -22dBm)
(7)	AT?CONNECTINDICATOR	0 connect indicator low (default) (0 = output low; 1 = output high)
(8)	AT?PHYMODE	0 PHY mode 1Mbps (default) (0 = 1Mbps; 1 = 2Mbps)
(9)	AT?WAKEUP	0 wakeup low (default) (0 = low active; 1 = high active)
(10)	AT?ADVTIME	0000 (default: Hex format only , forever advertising with no timeout, tttt: 0x0000)
(11)	AT?CONNECTINTERVALMODE	0 connect interval mode 0 (default) (0 = fixed connection interval for iOS/Android APP usage 1 = fixed connection interval for central usage 2 = Programmable connection interval for iOS/Android APP usage)

No.	Command	Response
(12)	AT?SERIALNO	Display “ no data! ” string (default)
(13)	AT?ADCVALUE	Value varies from input voltage (0v ~ +3.3v)
(14)	AT?RESPONSE	1 response en (default) (0 = disable response; 1 = enable response)
(15)	AT?CONNECTINTERVALTIME	006400C8 (default: Hex format only , 100ms min. connection interval / 200ms Max. connection interval, ttttttt: 0x006400C8)
(16)	AT?BASEUUID	9ECADC240EE5A9E093F3A3B50000406E (default: Hex format only , xx: 0x9ECADC240EE5A9E093F3A3B50000406E)
(17)	AT?SERVICEUUID	0001 (default: Hex format only , uuuu: 0x0001)
(18)	AT?TXCHARACTERUUID	0003 (default: Hex format only , uuuu: 0x0003)
(19)	AT?RXCHARACTERUUID	0002 (default: Hex format only , uuuu: 0x0002)
(20)	AT?ADVINTERVALTIME	0064 (default: Hex format only , 100 ms)
(21)	AT?CONNECTRSSI	-47 (dBm, value varies from RSSI)

2.6. Default Info

No.	Description	Default
(1)	Device name	Raytac AT-UART
(2)	Base UUID	0x9E, 0xCA, 0xDC, 0x24, 0x0E, 0xE5, 0xA9, 0xE0 0x93, 0xF3, 0xA3, 0xB5, 0x00, 0x00, 0x40, 0x6E
(3)	Service UUID	0x0001 TX characteristic: 0x0003; RX characteristic: 0x0002
(4)	Baud rate	115200bps,n,8,1
(5)	Status of flow control	Disabled
(6)	RF TX power	+7dBm
(7)	Logic of BT connecting indicator	Output set as logic low when BT is connecting
(8)	PHY mode	1Mbps
(9)	Logic of wake-up pin	Set logic low to wake up in deep sleep
(10)	Advertising time	Forever advertising with no timeout
(11)	Connection interval mode	Set at min. 20ms and Max. 40ms for iOS/Android usage
(12)	Serial number	Display " no data! " string
(13)	ADC value	Value varies from input voltage between 0x0000 ~ 0x03FFF (Hex).
(14)	State of response	Enabled
(15)	Connection Command mode	Disabled
(16)	Advertising Interval	0x0064 Advertising interval is 100 ms

2.7. Pin Assignment

Pin No.	Name	Pin Function	Description
(1)	GND	Ground	The pad must be connected to a solid ground plane
	P1.09	Digital I/O	General-purpose I/O
(2)	ASO [2]	Digital I/O	TAMPC active shield 2 output
	RADIO [0]	Digital I/O	RADIO DFEGPIO
	P1.10	Digital I/O	General-purpose I/O
(3)	ASI [2]	Digital I/O	TAMPC active shield 2 input
	RADIO [1]	Digital I/O	RADIO DFEGPIO
	P1.11	Digital I/O	General-purpose I/O Clock pin
(4)	ASO [3]	Digital I/O	TAMPC active shield 3 output
	RADIO [2]	Digital I/O	RADIO DFEGPIO
	AIN4	Analog input	Analog input
	P1.12	Digital I/O	General-purpose I/O Clock pin
(5)	ASI [3]	Digital I/O	TAMPC active shield 3 input
	RADIO [3]	Digital I/O	RADIO DFEGPIO
	AIN5	Analog input	Analog input
	P1.13	Digital I/O	General-purpose I/O
(6)	RADIO [4]	Digital I/O	RADIO DFEGPIO
	AIN6	Analog input	Analog input
	P1.14	Digital I/O	General-purpose I/O
(7)	RADIO [5]	Digital I/O	RADIO DFEGPIO
	AIN7	Analog input	Analog input
(8)	DECD	Power	0.9 V regulator supply decoupling
(9)	DCC	Power	DC/DC regulator output
(10)	GND	Ground	The pad must be connected to a solid ground plane
(11)	VDD_NRF	Power	Power-supply pin
	P1.00	Digital I/O	General-purpose I/O
(12)	XL1	Analog input	Connection for 32.768kHz crystal

Pin No.	Name	Pin Function	Description
(13)	P1.01	Digital I/O	General-purpose I/O
	XL2	Analog input	Connection for 32.768kHz crystal
(14)	GND	Ground	The pad must be connected to a solid ground plane
(15)	P1.02	Digital I/O	General-purpose I/O
	NFC1	NFC input	NFC antenna connection
(16)	P1.03	Digital I/O	General-purpose I/O Clock pin
	NFC2	NFC input	NFC antenna connection
(17)	P1.04	Digital I/O	General-purpose I/O Clock pin
	ASO [0]	Digital I/O	TAMPC active shield 0 output
	AIN0	Analog input	Analog input
(18)	P1.05	Digital I/O	General-purpose I/O
	ASI [0]	Digital I/O	TAMPC active shield 0 input
	RADIO [6]	Digital I/O	RADIO DFEGPIO
	AIN1	Analog input	Analog input
(19)	P1.06	Digital I/O	General-purpose I/O
	ASO [1]	Digital I/O	TAMPC active shield 1 output
	AIN2	Analog input	Analog input
(20)	P1.07	Digital I/O	General-purpose I/O
	ASI [1]	Digital I/O	TAMPC active shield 1 input
	AIN3	Analog input	Analog input
(21)	P1.08	Digital I/O	General-purpose I/O GRTC CLKOUTFAST Clock pin
	EXTREF	Analog input	External reference for SAADC
(22)	P2.00	Digital I/O	General-purpose I/O SPIM DCX UARTE RXD FLPR.4 QSPI D3

Pin No.	Name	Pin function	Description
(23)	P2.01	Digital I/O	General-purpose I/O
			SPIM SCK
			SPIS SCK
			FLPR.0
			QSPI SCK
			Clock pin
(24)	P2.02	Digital I/O	General-purpose I/O
			SPIM SDO
			SPIS SDO
			UARTE TXD
			FLPR.1
			QSPI D0
(25)	P2.03	Digital I/O	Serial wire output (SWO)
			General-purpose I/O
			FLPR.3
(26)	GND	Ground	QSPI D2
			The pad must be connected to a solid ground plane
(27)	P2.04	Digital I/O	General-purpose I/O
			SPIM SDI
			SPIS SDI
			UARTE CTS
			FLPR.2
			QSPI D1
(28)	P2.05	Digital I/O	General-purpose I/O
			SPIM CS
			SPIS CS
			UARTE RTS
			FLPR.5
			QSPI CS

Pin No.	Name	Pin function	Description
(29)	P2.06	Digital I/O	General-purpose I/O
			FLPR.6
			SPIM SCK
			SPIS SCK
			Clock pin
	TRACECLK	Digital I/O	Trace clock
(30)	P2.07	Digital I/O	General-purpose I/O
			FLPR.7
			SPIM DCX
			UARTE RXD
	SWO		Serial wire output (SWO)
(31)	P2.08	Digital I/O	General-purpose I/O
			FLPR.8
			SPIM SDO
			SPIS SDO
			UARTE TXD
	TRACEDATA [1]	Digital I/O	Trace data
(32)	P2.09	Digital I/O	General-purpose I/O
			FLPR.9
			SPIM SDI
			SPIS SDI
			UARTE CTS
	TRACEDATA [2]	Digital I/O	Trace data
(33)	P2.10	Digital I/O	General-purpose I/O
			FLPR.10
			SPIM CS
			SPIS CS
			UARTE RTS
	TRACEDATA [3]	Digital I/O	Trace data
(34)	P0.00	Digital I/O	General-purpose digital I/O
(35)	P0.01	Digital I/O	General-purpose digital I/O

Pin No.	Name	Pin function	Description
(36)	SWDIO	Debug	Serial wire data. Bidirectional with standard-drive and on-chip pull-down.
(37)	SWDCLK	Debug	Serial wire clock. Input with on-chip pull-up.
(38)	P0.03	Digital I/O	General-purpose I/O GRTC PWM Clock pin
(39)	RESET	Reset	Pin reset with on-chip pull-up (low active)
(40)	P0.04	Digital I/O	General-purpose I/O GRTC CLKOUT32K Clock pin
(41)	P0.02	Digital I/O	General-purpose digital I/O
(42) (43)	GND	Ground	The pad must be connected to a solid ground plane (Only for AN54LQ-15 Model)

3. How to Control via External MCU

3.1. How to Send AT Commands

- **When BT is NOT connected, for ALL commands**

1. Output low to [UART PD](#) pin to enable UART interface. Please keep it LOW during the whole time when sending AT commands.
2. Send any AT commands you want. **Please wait for at least 250 ms between sending each command.**

We recommend sending corresponding “Read” command ([section 2.4](#)) right after the delay to know whether the writing is successful before moving on to step 3 to save your settings.

Please prolong the delay (over 250 ms) when writing or/and reading is not successful.

3. **Send command “ AT+RESET ” (not HW reset) to save all your settings.**

After sending the "AT+RESET" command, do NOT write any commands and wait at least 1 second to flash to update. Keep the power on during the whole period.

4. Output high or NC to [UART PD](#) pin to turn off UART interface.

- **When BT is connected**

Write: AT+DISCONNECT, AT+SLEEP

Read: AT?ADCVALUE, AT?CONNECTRSSI

1. Output low to [UART PD](#) pin to enable UART interface. Please keep it LOW during the whole time when sending AT commands.
2. Output low to [flash default](#) pin to enable the module to receive AT commands when BT is connected. Please keep it LOW during the whole time when sending AT commands. Or send AT+COMMANDMODEEN to enable the module to receive AT commands when BT is connected.
3. Send “AT?ADCVALUE” or “AT?CONNECTRSSI” or “AT+DISCONNECT” or “AT+SLEEP”.
4. Output high or NC to [UART PD](#) pin to turn off UART interface.

3.2. How to return to setting of default flash

*** Only when BT is NOT connected ***

1. Output low to **UART PD** pin to enable UART interface. Please keep it LOW during the whole time when transmitting data.
2. Output high or NC to **UART PD** pin to turn off UART interface.

3.3. How to Return to Flashed Default Setting

*** Only when BT is NOT connected ***

*** Note that default baud rate is “115200bps,n,8,1”. For other default, please check [“2.6 Default Info”](#)**

● Use Hardware Method

1. Read **indicator** pin first to check if BT is *NOT* in connection.
2. Output a low pulse to **flash default** pin, then system will return to default setting.

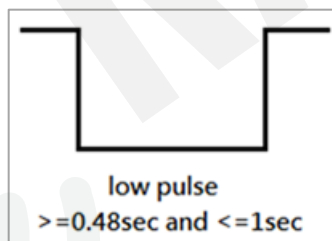

● Use Software method

1. Output low to **UART PD** pin to enable UART interface. Please keep it LOW during the whole time when sending AT commands.
2. Send command “AT+DEFAULT”, then system will return to default setting.

4. Test Report

All testing is done under **PHY mode at 1M bps.**

4.1. Current Test

*** The “Advertising Current” and “Connected Current” data presented below are based on measurements taken in DC-DC mode, with an inductor (L1) connected to the DCC pin.***

Logic of UART PD pin	Advertising Current	Connected Current
High	0.30 mA	0.25mA
Low	0.60 mA	0.55 mA

Sleep Mode	Logic of UART PD pin	Sleep Current
	High	2 uA
	Low	2 uA

4.2. Throughput Test

Here **D.L.** means “**Data Length**” and **D.I.** means “**Data Interval**” in the table.

- MCU → Peripheral (AN54LQ-15 - AT) → Central → Console

Central Connection Interval	Peripheral Connection Interval	Baud Rate	Flow Control	MCU D.L. (bytes)	MCU D.I. (ms)	Total D.L. (bytes)	Total Trans. Time (sec)	Data Rate (k-bytes/sec)
min = 20ms Max = 75ms	min = 20ms Max = 40ms	9600	X	244	260	999424	1075	0.93
			V					
min = 20ms Max = 75ms	min = 20ms Max = 40ms	115200	X	244	30	999424	124	8
			V					
min = 20ms Max = 75ms	min = 20ms Max = 40ms	460800	X	244	18	999424	75	13.3
			V					
min = Max = 8ms	min = Max = 8ms	9600	X	244	260	999424	1075	0.93
			V					
min = Max = 8ms	min = Max = 8ms	115200	X	244	30	999424	124	8
			V					
min = Max = 8ms	min = Max = 8ms	460800	X	244	12	999424	50	19.9
			V					

● MCU → Central → Peripheral (AN54LQ-15 - AT) → Console

Central Connection Interval	Peripheral Connection Interval	Baud Rate	Flow Control	MCU D.L. (bytes)	MCU D.I. (ms)	Total D.L. (bytes)	Total Trans. Time (sec)	Data Rate (k-bytes/sec)
min = 20ms Max = 75ms	min = 20ms Max = 40ms	9600	X	244	250	999424	1,042	0.96
			V					
min = 20ms Max = 75ms	min = 20ms Max = 40ms	115200	X	244	25	999424	104	9.6
			V					
min = 20ms Max = 75ms	min = 20ms Max = 40ms	460800	X	244	12	999424	50	19.9
			V					
min = Max = 8ms	min = Max = 8ms	9600	X	244	250	999424	1,042	0.96
			V					
min = Max = 8ms	min = Max = 8ms	115200	X	244	25	999424	104	9.6
			V					
min = Max = 8ms	min = Max = 8ms	460800	X	244	11	999424	46	21.7
			V					

5. Product dimension

5.1. PCB dimensions & Pin indication

• AN54LQ-AT

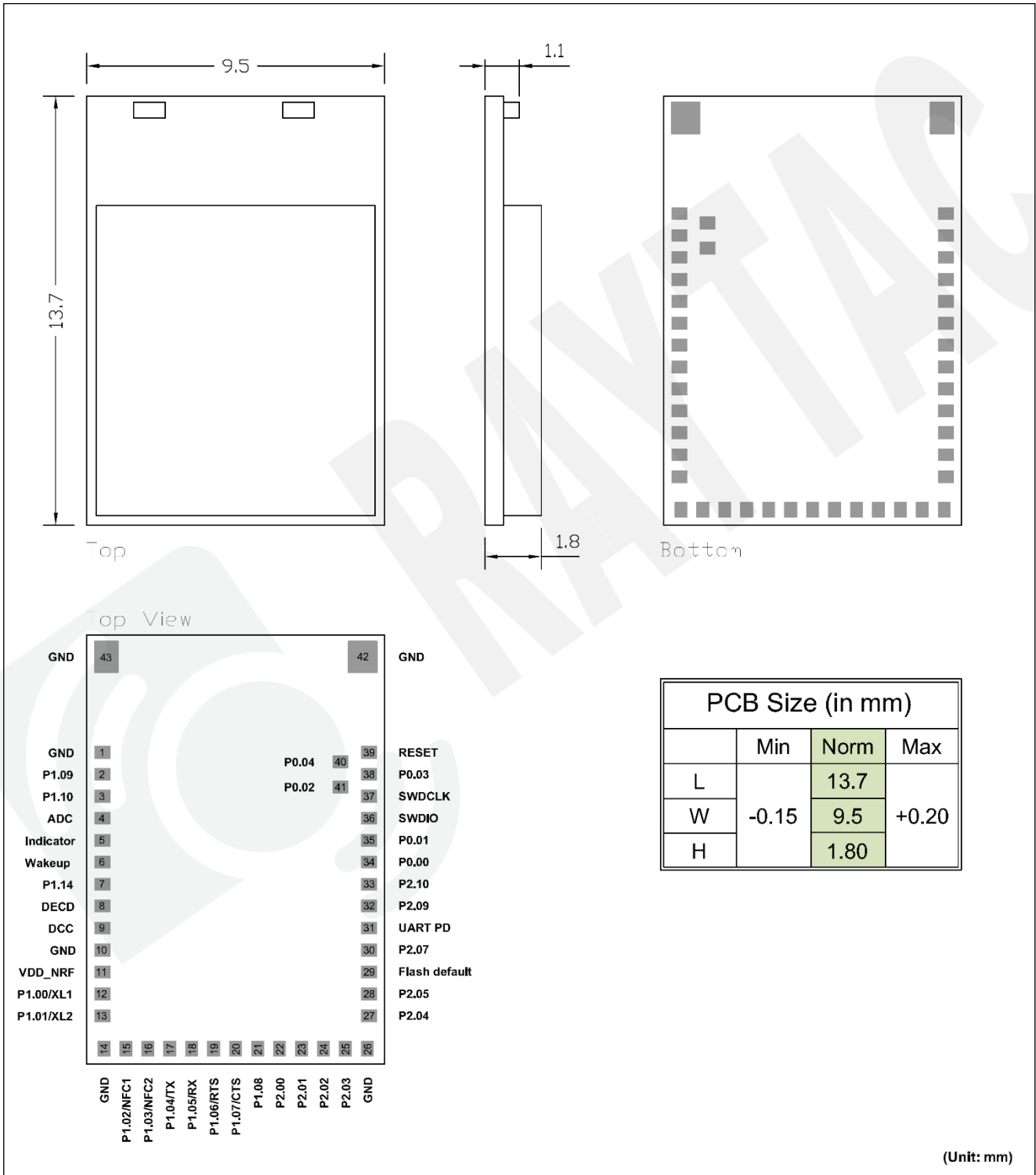

5.2. Recommended layout of solder pad

Graphs are all in Top View, Unit in mm.

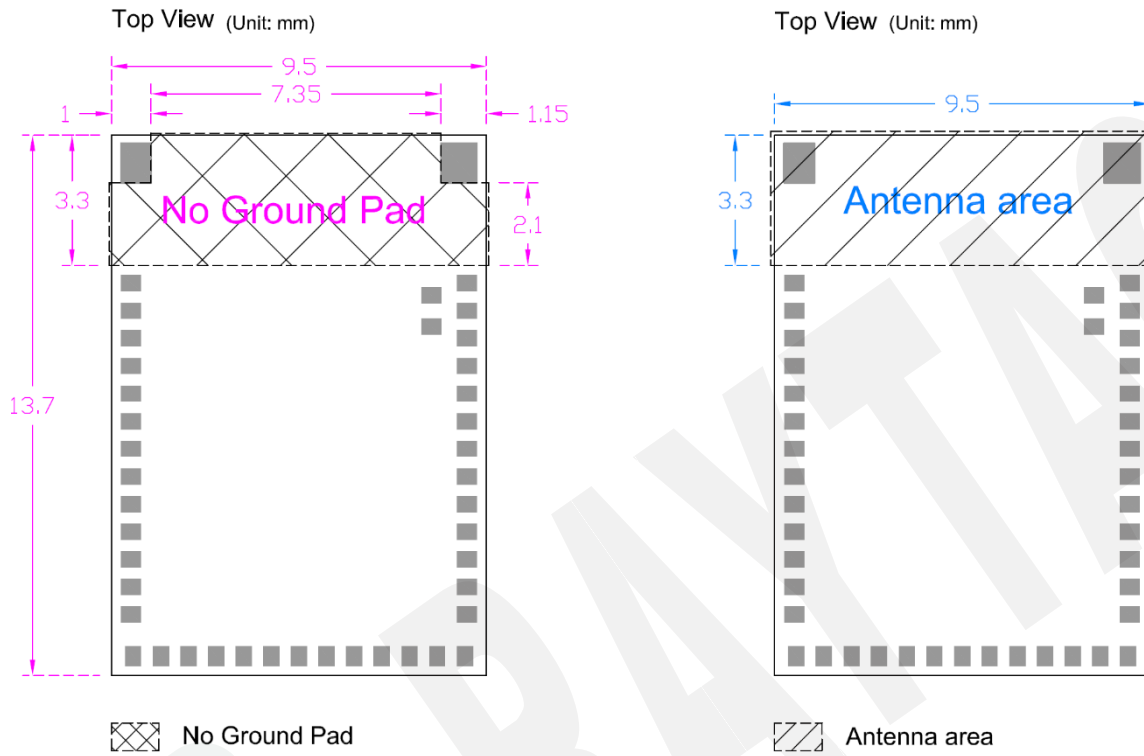

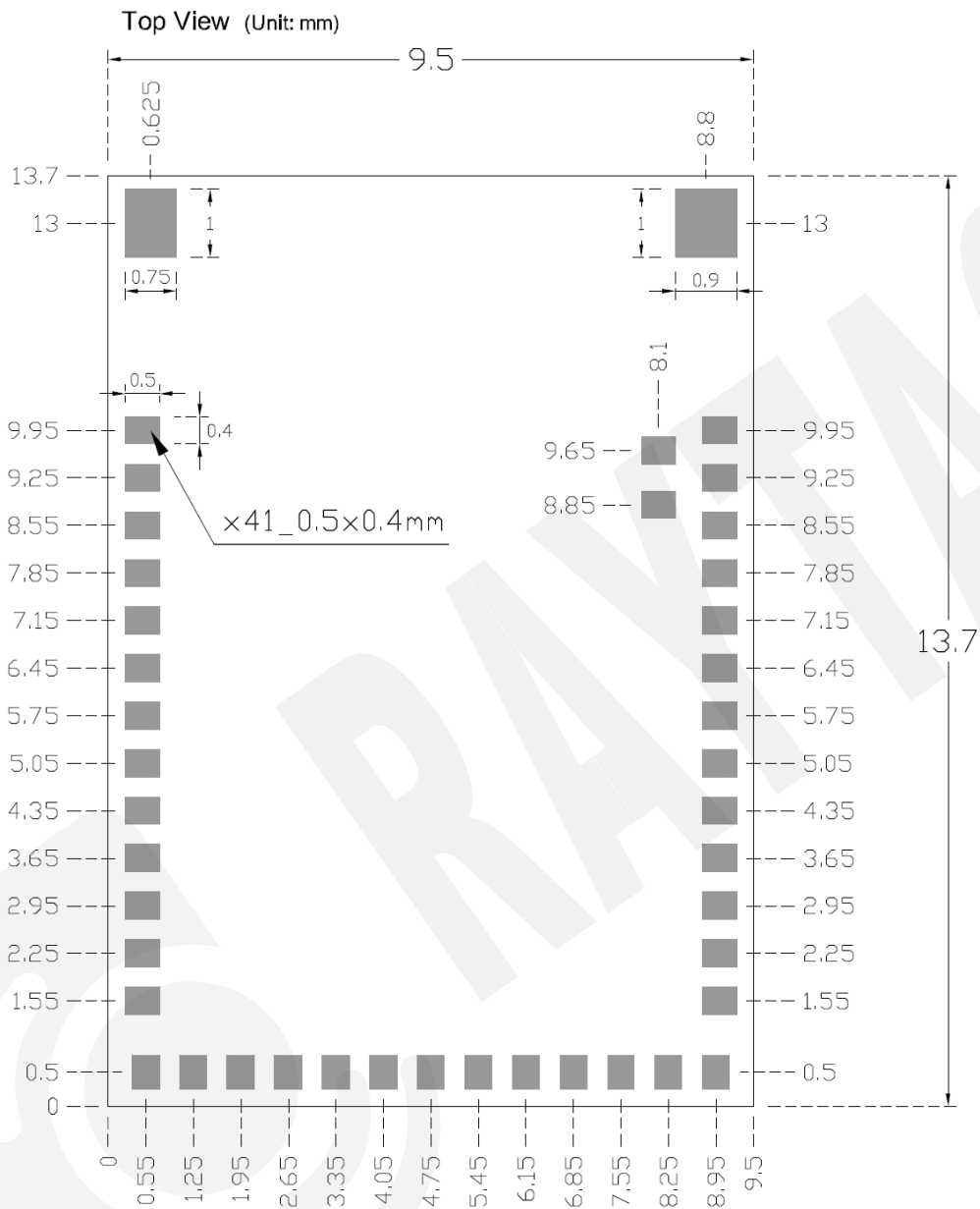

5.3. RF layout suggestion (aka Keep-Out Area)

Please ensure that no ground pad overlaps the “No Ground-Pad Area”, as shown in the images below. This is important to maintain antenna performance and to prevent potential short circuits within the module.

You are welcome to send us your design files for review at sales@raytac.com or to your Raytac contact with email subject titled: “Layout Review – Raytac Model No. – Your company name”

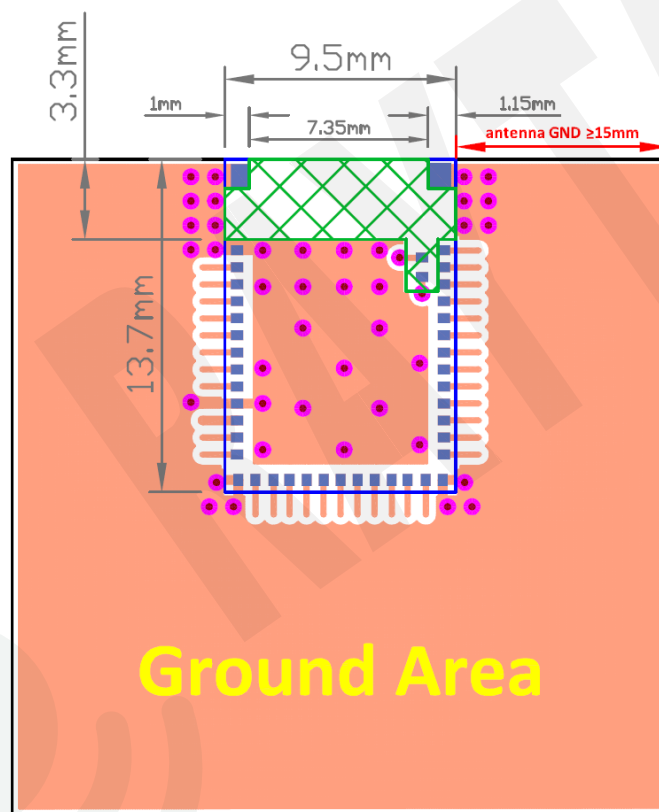

Top View

 **No Ground-Pad Area**

Note: Recommended antenna GND reference distance: $\geq 15\text{mm}$

Please add via holes in GROUND area as many as possible, especially around the four corners.

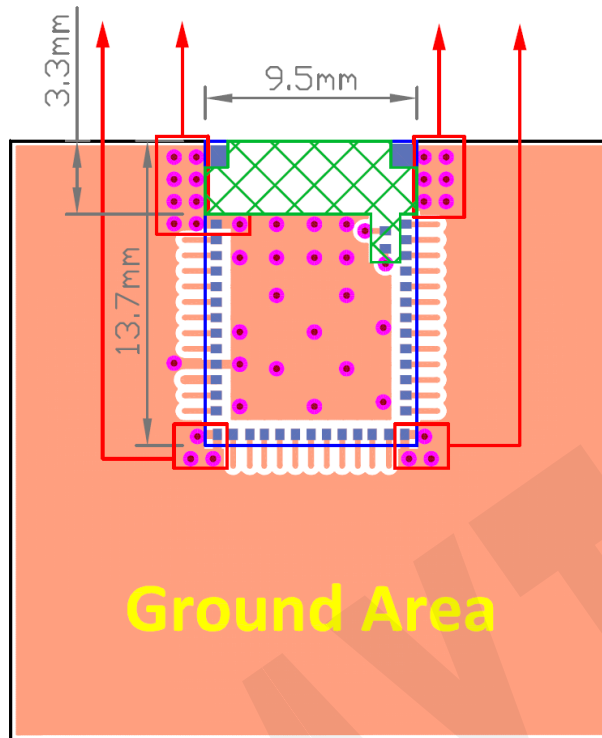

Top View

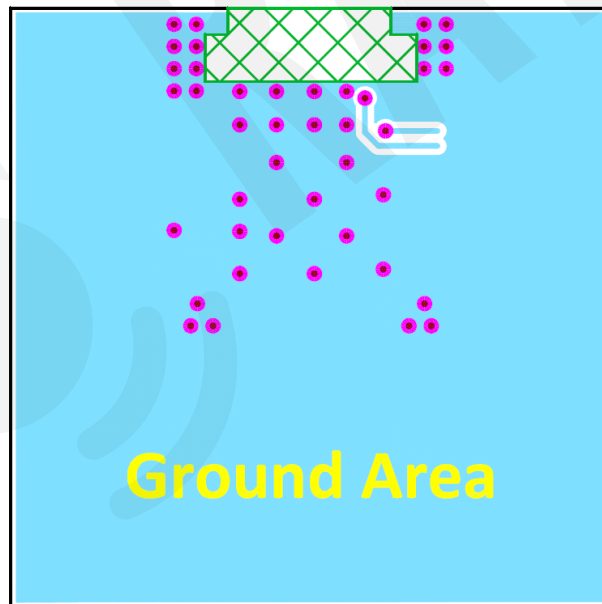

Perspective View

 No Ground-Pad Area

5.4. Footprint & design guide

Please visit "[Support](#)" page of our website to download. The package includes footprint, 2D/3D drawing, and reflow graph/solder profile.

6. Main chip solution

RF IC	Crystal Frequency
Nordic NRF54L15 / QFN	32MHz

The 32MHz crystal is already integrated inside the module.

The crystal load capacitance has already been optimized in the module design.



7. Shipment packaging information

Model	Antenna	Photo
AN54LQ-AT	Chip/Ceramic	

- Unit Weight of Module:
- AN54LQ-AT : 0.51 g (± 0.02 g) ;
- Packaging type: Tray or Tape & Reel.

	Tray (PET / APET)	Tape & Reel
MPQ (Min. Package Q'ty)	88 pcs per tray	1,500 pcs per reel
Carton Contents (per carton)	1,760 pcs	1,500 pcs
Carton Dimension (L) x (W) x (H) cm	37 x 21 x 13	37 x 36 x 6
Gross Weight	about 2.6 kgs	about 2.1 kgs

7.1. Marking on metal shield

Label context on metal shield is as below:

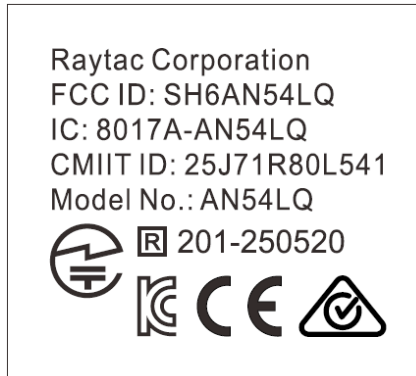

7.2. Packaging Info

7.2.1. Tray Packaging

Anti-static trays are specifically designed for mass production and are fully compatible with standard SMT automated assembly lines. To optimize manufacturing efficiency, standard PET or APET anti-static materials are utilized, both ensuring excellent mechanical stability and ESD protection.

Both tray variants share identical physical dimensions and structural designs, differing only in the text marking printed on the surface for material identification.

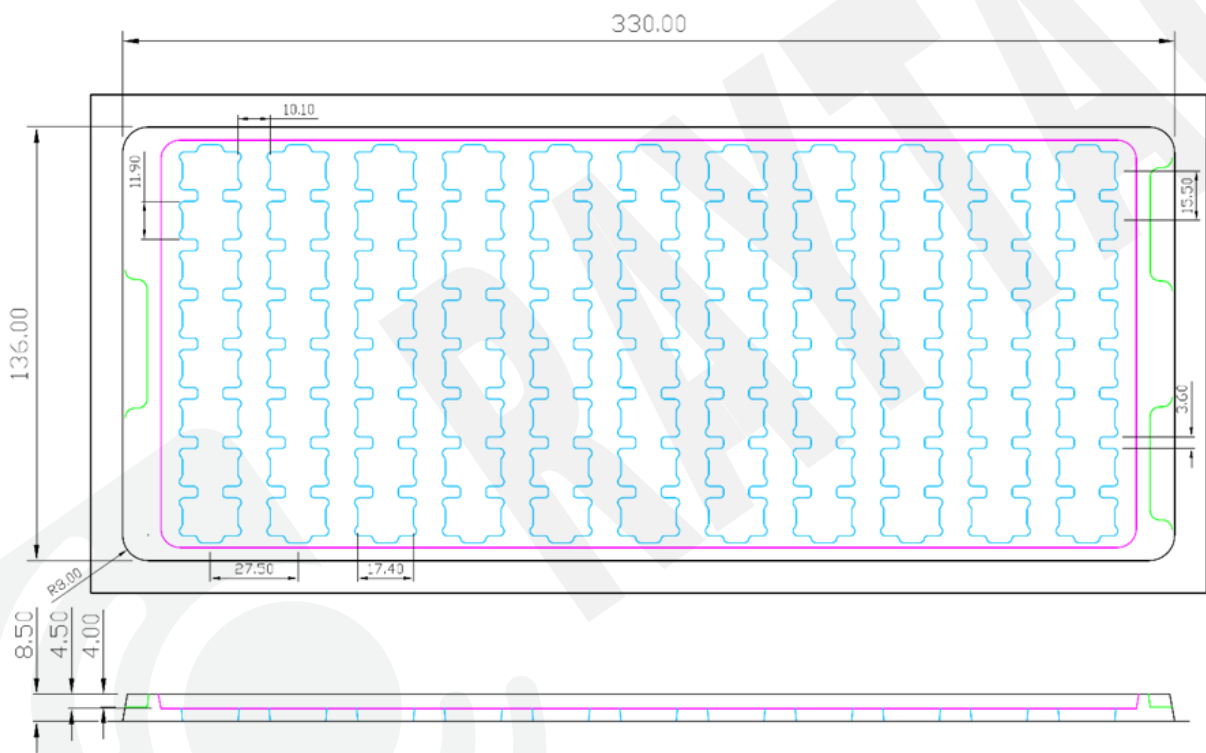

Unit: mm

Figure 1: Tray specification with PET marking

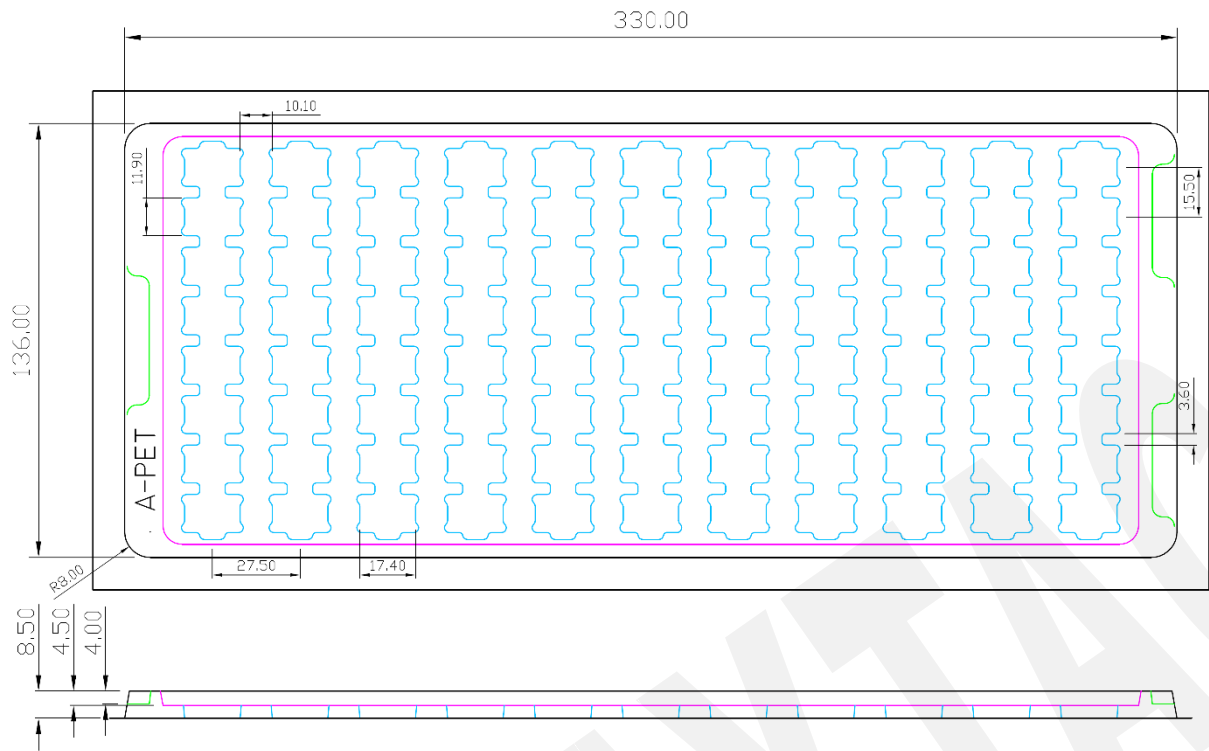

Unit: mm

Figure 2: Tray specification with APET marking

7.2.2. Reel packaging

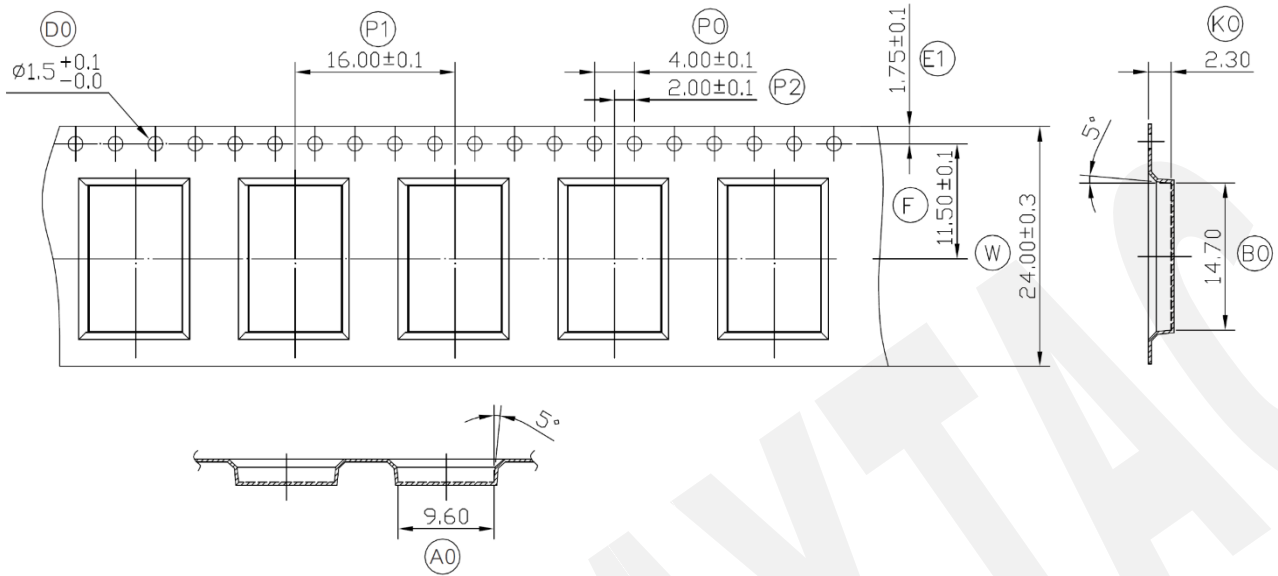

W	24.00	± 0.30
P1	16.00	± 0.10
E1	1.75	± 0.10
F	11.50	± 0.10
D0	1.50	$+0.1/-0$
P0	4.00	± 0.10
P2	2.00	± 0.10
A0	9.60	± 0.10
B0	14.70	± 0.10
K0	2.30	± 0.10
T	0.30	± 0.05

7.3. Order code

Each model has two options of packaging. Please use following part no. when placing order to us.

Model	Tray	Tape & Reel
AN54LQ-AT	(PET) MD-240A8-027 (APET) MD-240A8-027A	MD-240A8-027R

MPQ of Reel packaging is 1,500 pcs and Tray packaging is 88 pcs.



RAYTRAC

8. Specification

Any technical spec shall refer to Nordic's official documents as final reference. Contents below are from "[nRF54L15 nRF54L10 nRF54L05 Product Specification v1.0](#)", please click to download full spec.

8.1. Recommended operating conditions

Symbol	Parameter	Min.	Nom.	Max.	Units
VDD	VDD supply voltage	1.7		3.6	V
VDD _{EXT}	VDD supply voltage under extended operating temperature	1.7		3.4	V
VDD _{POR}	VDD supply voltage needed during power-on reset	1.75			V
TA	Operating temperature	-40	25	85	°C
TA _{EXT}	Extended operating temperature	85		105	°C
T _{RST}	Recommended storage temperature			40	°C
RH _{RST}	Recommended storage relative humidity			90	%

The operating conditions are the physical parameters that the device can operate within.

8.2. Radio specifications

8.2.1. General radio characteristics

Symbol	Parameter	Min.	Typ.	Max.	Units
f _{OP}	Operating frequencies	2400		2500	MHz
f _{P_{LL},CH,SP}	Channel spacing		1		MHz
f _{DELTA,1M}	Frequency deviation @ 1 Mbps		± 160		kHz
f _{DELTA,BLE,1M}	Frequency deviation @ Bluetooth LE 1 Mbps		±250		kHz
f _{DELTA,2M}	Frequency deviation @ 2 Mbps		±320		kHz
f _{DELTA,BLE,2M}	Frequency deviation @ Bluetooth LE 2 Mbps		±500		kHz
f _{DELTA,4M}	Frequency deviation @ 4 Mbps		±1000		kHz
f _{SKBPS}	On-the-air data rate	125		4000	kbps
f _{chip, IEEE 802.15.4}	Chip rate in IEEE 802.15.4 mode		2000		kchip/s

8.2.2. Radio current consumption (Transmitter)

Symbol	Description	Min.	Typ.	Max.	Units
$I_{TX,MaxdBm,QFN}$	TX only run current for QFN package, P_{RF} at maximum power setting		9.1		mA
$I_{TX,MaxdBm,CSP}$	TX only run current for CSP package, P_{RF} at maximum power setting		9.7		mA
$I_{TX,0dBm}$	TX only run current, $P_{RF} = 0$ dBm		3.7		mA
$I_{TX,MINUS4dBm}$	TX only run current, $P_{RF} = -4$ dBm		2.8		mA
$I_{TX,MINUS8dBm}$	TX only run current, $P_{RF} = -8$ dBm		2.2		mA
$I_{TX,MINUS12dBm}$	TX only run current $P_{RF} = -12$ dBm		1.9		mA
$I_{TX,MINUS16dBm}$	TX only run current $P_{RF} = -16$ dBm		1.7		mA
$I_{TX,MINUS40dBm}$	TX only run current $P_{RF} = -40$ dBm		1.2		mA

8.2.3. Radio current consumption (Receiver)

Symbol	Description	Min.	Typ.	Max.	Units
$I_{RX,1M}$	RX only run current, 1 Mbps/1 Mbps Bluetooth LE mode		2.1		mA
$I_{RX,2M}$	RX only run current, 2 Mbps/2 Mbps Bluetooth LE mode		2.1		mA
$I_{START,RX,1M}$	RX start-up current, 1 Mbps/1 Mbps Bluetooth LE mode		1.6		mA

8.2.4. Transmitter specification

Symbol	Description	Min.	Typ.	Max.	Units
$P_{RF,QFN}$	Maximum output power for QFN package		7		dBm
$P_{RF,CSP}$	Maximum output power for CSP package		8		dBm
$P_{RF,CR}$	RF power accuracy	-2		2	dB
$P_{RF1,BLE1M,2MHz}$	Adjacent Channel Transmit Power 2 MHz (1 Mbps Bluetooth LE mode)		-48		dBc
$P_{RF1,BLE1M,3MHz}$	Adjacent Channel Transmit Power 3 MHz (1 Mbps Bluetooth LE mode)		-54		dBc
$P_{RF1,BLE2M,4MHz}$	Adjacent Channel Transmit Power 4 MHz (2 Mbps Bluetooth LE mode)		-51		dBc
$P_{RF1,BLE2M,6MHz}$	Adjacent Channel Transmit Power 6 MHz (2 Mbps Bluetooth LE mode)		-56		dBc
E_{vm}	Error vector magnitude in IEEE 802.15.4 mode		2		%rms
$P_{harm2nd, IEEE 802.15.4}$	2nd harmonics in IEEE 802.15.4 mode		-63		dBm
$P_{harm3rd, IEEE 802.15.4}$	3rd harmonics in IEEE 802.15.4 mode		68		dBm

8.2.5. Receiver operation

Symbol	Description	Min.	Typ.	Max.	Units
P _{RX,MAX}	Maximum received signal strength at < 0.1% PER		0		dBm
P _{SENS,IT,1M}	Sensitivity, 1 Mbps nRF mode ideal transmitter ⁴		-93		dBm
P _{SENS,IT,2M}	Sensitivity, 2 Mbps nRF mode ideal transmitter ⁴		-90		dBm
P _{SENS,IT,4M}	Sensitivity, 4 Mbps nRF mode ideal transmitter ⁴		-90		dBm
P _{SENS,IT,SP,1M,BLE}	Sensitivity, 1 Mbps Bluetooth LE ideal transmitter, packet length ≤ 37 bytes BER = 1E-3 ⁵		-96 ⁶		dBm
P _{SENS,IT,LP,1M,BLE}	Sensitivity, 1 Mbps Bluetooth LE ideal transmitter, packet length ≥ 128 bytes BER = 1E-4		-95		dBm
P _{SENS,IT,SP,2M,BLE}	Sensitivity, 2 Mbps Bluetooth LE ideal transmitter, packet length ≤ 37 bytes		-94		dBm
P _{SENS,IT,BLE LE125k}	Sensitivity, 125 kbps Bluetooth LE mode		-104		dBm
P _{SENS,IT,BLE LE500k}	Sensitivity, 500 kbps Bluetooth LE mode		-99		dBm
P _{SENS,IEEE 802.15.4}	Sensitivity in IEEE 802.15.4 mode		-102		dBm

⁴ Typical sensitivity applies when `RXADDRESS.ADDR0` is used for receiver address. When `RXADDRESS.ADDR[1 ... 7]` are used for receiver address, the typical sensitivity for this mode is degraded by 3 dB.

⁵ As defined in the Bluetooth Core Specification v4.0 Volume 6: Core System Package (Low Energy Controller Volume).

⁶ QFN package sensitivity is degraded by approximately 1 dB compared to the provided value.

8.2.6. RX selectivity

Symbol	Description	Min.	Typ.	Max.	Units
C/I _{1M,co-channel}	1 Mbps mode, co-channel interference		9		dB
C/I _{1M,-1MHz}	1 Mbps mode, Adjacent (-1 MHz) interference		-4		dB
C/I _{1M,+1MHz}	1 Mbps mode, Adjacent (+1 MHz) interference		-9		dB
C/I _{1M,-2MHz}	1 Mbps mode, Adjacent (-2 MHz) interference		-28		dB
C/I _{1M,+2MHz}	1 Mbps mode, Adjacent (+2 MHz) interference		-40		dB
C/I _{1M,-3MHz}	1 Mbps mode, Adjacent (-3 MHz) interference		-39		dB
C/I _{1M,+3MHz}	1 Mbps mode, Adjacent (+3 MHz) interference		-43		dB
C/I _{1M,±6MHz}	1 Mbps mode, Adjacent (≥6 MHz) interference		-48		dB
C/I _{1MBLE,co-channel}	1 Mbps Bluetooth LE mode, co-channel interference		6		dB
C/I _{1MBLE,-1MHz}	1 Mbps Bluetooth LE mode, Adjacent (-1 MHz) interference		-2		dB
C/I _{1MBLE,+1MHz}	1 Mbps Bluetooth LE mode, Adjacent (+1 MHz) interference		-6		dB
C/I _{1MBLE,-2MHz}	1 Mbps Bluetooth LE mode, Adjacent (-2 MHz) interference		-29		dB
C/I _{1MBLE,+2MHz}	1 Mbps Bluetooth LE mode, Adjacent (+2 MHz) interference		-43		dB
C/I _{1MBLE,>3MHz}	1 Mbps Bluetooth LE mode, Adjacent (≥3 MHz) interference		-46		dB

Symbol	Description	Min.	Typ.	Max.	Units
$C/I_{1\text{MBLE,image}}$	Image frequency interference		-29		dB
$C/I_{1\text{MBLE,image},1\text{MHz}}$	Adjacent (1 MHz) interference to in-band image frequency		-39		dB
$C/I_{2\text{M,co-channel}}$	2 Mbps mode, co-channel interference		10		dB
$C/I_{2\text{M},-2\text{MHz}}$	2 Mbps mode, Adjacent (-2 MHz) interference		-5		dB
$C/I_{2\text{M},+2\text{MHz}}$	2 Mbps mode, Adjacent (+2 MHz) interference		-9		dB
$C/I_{2\text{M},-4\text{MHz}}$	2 Mbps mode, Adjacent (-4 MHz) interference		-27		dB
$C/I_{2\text{M},+4\text{MHz}}$	2 Mbps mode, Adjacent (+4 MHz) interference		-42		dB
$C/I_{2\text{M},-6\text{MHz}}$	2 Mbps mode, Adjacent (-6 MHz) interference		-38		dB
$C/I_{2\text{M},+6\text{MHz}}$	2 Mbps mode, Adjacent (+6 MHz) interference		-45		dB
$C/I_{2\text{M},\geq 12\text{MHz}}$	2 Mbps mode, Adjacent (≥ 12 MHz) interference		-50		dB
$C/I_{2\text{MBLE,co-channel}}$	2 Mbps Bluetooth LE mode, co-channel interference		6		dB
$C/I_{2\text{MBLE},-2\text{MHz}}$	2 Mbps Bluetooth LE mode, Adjacent (-2 MHz) interference		-2		dB
$C/I_{2\text{MBLE},+2\text{MHz}}$	2 Mbps Bluetooth LE mode, Adjacent (+2 MHz) interference		-6		dB
$C/I_{2\text{MBLE},-4\text{MHz}}$	2 Mbps Bluetooth LE mode, Adjacent (-4 MHz) interference		-29		dB
$C/I_{2\text{MBLE},+4\text{MHz}}$	2 Mbps Bluetooth LE mode, Adjacent (+4 MHz) interference		-44		dB
$C/I_{2\text{MBLE},\geq 6\text{MHz}}$	2 Mbps Bluetooth LE mode, Adjacent (≥ 6 MHz) interference		-46		dB
$C/I_{4\text{M,co-channel}}$	4 Mbps mode, co-channel interference		6		dB
$C/I_{4\text{M},-4\text{MHz}}$	4 Mbps mode, Adjacent (-4 MHz) interference		-4		dB
$C/I_{4\text{M},+4\text{MHz}}$	4 Mbps mode, Adjacent (+4 MHz) interference		-11		dB
$C/I_{4\text{M},-8\text{MHz}}$	4 Mbps mode, Adjacent (-8 MHz) interference		-27		dB
$C/I_{4\text{M},+8\text{MHz}}$	4 Mbps mode, Adjacent (+8 MHz) interference		-46		dB
$C/I_{4\text{M},-12\text{MHz}}$	4 Mbps mode, Adjacent (-12 MHz) interference		-40		dB
$C/I_{4\text{M},+12\text{MHz}}$	4 Mbps mode, Adjacent (+12 MHz) interference		-50		dB
$C/I_{4\text{M},\geq 24\text{MHz}}$	4 Mbps mode, Adjacent (≥ 24 MHz) interference		-56		dB
$C/I_{2\text{MBLE,image}}$	Image frequency interference		-29		dB
$C/I_{2\text{MBLE,image},2\text{MHz}}$	Adjacent (2 MHz) interference to in-band image frequency		-38		dB

RX selectivity with equal modulation on interfering signal ⁷

⁷ Desired signal level at $P_{IN} = -67$ dBm. One interferer is used, having equal modulation as the desired signal. The input power of the interferer where the sensitivity equals BER = 0.1% is presented.

Symbol	Description	Min.	Typ.	Max.	Units
C/I _{125k BLE LR,co-channel}	125 kbps Bluetooth LE LR mode, co-channel interference		1		dB
C/I _{125k BLE LR,-1MHz}	125 kbps Bluetooth LE LR mode, Adjacent (-1 MHz) interference		-13		dB
C/I _{125k BLE LR,+1MHz}	125 kbps Bluetooth LE LR mode, Adjacent (+1 MHz) interference		-16		dB
C/I _{125k BLE LR,-2MHz}	125 kbps Bluetooth LE LR mode, Adjacent (-2 MHz) interference		-36		dB
C/I _{125k BLE LR,+2MHz}	125 kbps Bluetooth LE LR mode, Adjacent (+2 MHz) interference		-52		dB
C/I _{125k BLE LR,≥3MHz}	125 kbps Bluetooth LE LR mode, Adjacent (≥3 MHz) interference		-55		dB
C/I _{125k BLE LR,image}	Image frequency interference		-36		dB
C/I _{IEEE 802.15.4,-5MHz}	IEEE 802.15.4 mode, Adjacent (-5 MHz) rejection		-35		dB
C/I _{IEEE 802.15.4,+5MHz}	IEEE 802.15.4 mode, Adjacent (+5 MHz) rejection		-38		dB
C/I _{IEEE 802.15.4,±10MHz}	IEEE 802.15.4 mode, Alternate (±10 MHz) rejection		-50		dB

8.2.7. RX intermodulation

Symbol	Description	Min.	Typ.	Max.	Units
P _{IMD,5TH,1M,BLE}	IMD performance, Bluetooth LE 1 Mbps, 5th offset channel, packet length ≤37 bytes		-19		dBm
P _{IMD,5TH,2M,BLE}	IMD performance, Bluetooth LE 2 Mbps, 5th offset channel, packet length ≤37 bytes		-16		dBm

RX intermodulation: Desired signal level at P_{IN} = -64 dBm. Two interferers with equal input power are used. The interferer closest in frequency is not modulated, the other interferer is modulated equal with the desired signal. The input power of the interferers where the sensitivity equals BER = 1E-3 is presented.

8.2.8. Radio timing parameters

Symbol	Description	Min.	Typ.	Max.	Units
$t_{TXEN,BLE,1M}$	Time between TXEN task and READY event after channel FREQUENCY configured (1 Mbps Bluetooth LE and 150 μ s TIFS)		140		μ s
$t_{TXEN,FAST,BLE,1M}$	Time between TXEN task and READY event after channel FREQUENCY configured (1 Mbps Bluetooth LE with fast ramp-up and 150 μ s TIFS)		40		μ s
$t_{TXDIS,BLE,1M}$	When in TX, delay between DISABLE task and DISABLED event for MODE = Nrf_1Mbit and MODE = Ble_1Mbit		2		μ s
$t_{RXEN,BLE,1M}$	Time between the RXEN task and READY event after channel FREQUENCY configured (1 Mbps Bluetooth LE)		134		μ s
$t_{RXEN,FAST,BLE,1M}$	Time between the RXEN task and READY event after channel FREQUENCY configured (1 Mbps Bluetooth LE with fast ramp-up)		40		μ s
$t_{RXDIS,BLE,1M}$	When in RX, delay between DISABLE task and DISABLED event for MODE = Nrf_1Mbit and MODE = Ble_1Mbit		1		μ s
$t_{TXDIS,BLE,2M}$	When in TX, delay between DISABLE task and DISABLED event for MODE = Nrf_2Mbit and MODE = Ble_2Mbit		2		μ s
$t_{RXDIS,BLE,2M}$	When in RX, delay between DISABLE task and DISABLED event for MODE = Nrf_2Mbit and MODE = Ble_2Mbit		1		μ s
$t_{TXEN,IEEE802.15.4}$	Time between TXEN task and READY event after channel FREQUENCY configured (IEEE 802.15.4 mode)		130		μ s
$t_{TXEN,FAST,IEEE802.15.4}$	Time between TXEN task and READY event after channel FREQUENCY configured (IEEE 802.15.4 mode with fast ramp-up)		40		μ s
$t_{TXDIS,IEEE802.15.4}$	When in TX, delay between DISABLE task and DISABLED event (IEEE 802.15.4 mode)		18		μ s
$t_{RXEN,IEEE802.15.4}$	Time between the RXEN task and READY event after channel FREQUENCY configured (IEEE 802.15.4 mode)		130		μ s
$t_{RXEN,FAST,IEEE802.15.4}$	Time between the RXEN task and READY event after channel FREQUENCY configured (IEEE 802.15.4 mode with fast ramp-up)		40		μ s
$t_{RXDIS,IEEE802.15.4}$	When in RX, delay between DISABLE task and DISABLED event (IEEE 802.15.4 mode)		0.2		μ s
$t_{RX\text{-to-TX}\text{ turnaround, IEEE802.15.4}}$	Maximum RX-to-TX turnaround time in IEEE 802.15.4 mode		17		μ s

8.2.9. RSSI specifications

Symbol	Description	Min.	Typ.	Max.	Units
RSSI _{ACC}	RSSI accuracy in the range -90 to -30 dBm		± 2		dB
RSSI _{RESOLUTION}	RSSI resolution		1		dB
RSSI _{PERIOD}	RSSI sampling time from RSSI _{START} task		0.25		μ s
RSSI _{SETTLE}	RSSI settling time after signal level change		15	20	μ s

8.3. GPIO electrical specification

Symbol	Description	Min.	Typ.	Max.	Units
V_{IH}	Input high voltage	$0.7 \times VDD$		VDD	V
V_{IL}	Input low voltage	VSS		$0.3 \times VDD$	V
$V_{OH,SD}$	Output high voltage, standard drive, 0.5 mA, $VDD \geq 1.7$ V	$VDD - 0.4$		VDD	V
$V_{OH,HDL}$	Output high voltage, high drive, 5 mA, $VDD \geq 2.7$ V	$VDD - 0.4$		VDD	V
$V_{OH,HDL}$	Output high voltage, high drive, 3 mA, $VDD \geq 1.7$ V	$VDD - 0.4$		VDD	V
$V_{OL,SD}$	Output low voltage, standard drive, 0.5 mA, $VDD \geq 1.7$ V	VSS		$VSS + 0.4$	V
$I_{OL,SD}$	Current at $VSS + 0.4$ V, output set low, standard drive, $VDD \geq 1.7$ V	1	3	4	mA
$I_{OL,HDL}$	Current at $VSS + 0.4$ V, output set low, high drive, $VDD \geq 1.7$ V	3			mA
$I_{OL,ED}$	Current at $VSS + 0.4$ V, output set low, extra drive, $VDD \geq 1.7$ V	16			mA
$I_{OH,SD}$	Current at $VDD - 0.4$ V, output set high, standard drive, $VDD \geq 1.7$ V	1	3	4	mA
$I_{OH,HDL}$	Current at $VDD - 0.4$ V, output set high, high drive, $VDD \geq 1.7$ V	4			mA
$I_{OH,ED}$	Current at $VDD - 0.4$ V, output set high, extra drive, $VDD \geq 1.7$ V	14			mA
$I_{GPIO,TOTAL}$	Recommended maximum sustained current drawn by all GPIOs			15	mA
$t_{HR,12pF}$	Rise/Fall time, high drive mode, 20–80%, 12 pF load ¹		4		ns
$t_{ER,12pF}$	Rise/Fall time, extra drive mode, 20–80%, 12 pF load ¹		0.9		ns
R_{PU}	Pull-up resistance	12	14	16	k Ω
R_{PD}	Pull-down resistance	12	14	18	k Ω
$t_{OE,ED}$	Output enable delay in extra drive mode			855	ns
C_{PAD}	Pad capacitance		1		pF
C_{PAD_NFC}	Pad capacitance on NFC pads		5		pF

8.4. Absolute maximum ratings

Parameter		Min.	Max.	Unit
Supply voltage				
VDD	VDD supply voltage	-0.3	3.9	V
VDD _{EXT}	VDD supply voltage under extended operating temperature	-0.3	3.7	V
I/O pin voltage				
V _{I/O} , VDD ≤ 3.6 V	IO voltage	-0.3	VDD + 0.3	V
V _{I/O} , VDD > 3.6 V	IO voltage	-0.3	3.9	V
V _{I/O,EXT} , VDD _{EXT} ≤ 3.4 V	IO voltage under extended operating temperature	-0.3	VDD + 0.3	V
V _{I/O,EXT} , VDD _{EXT} > 3.4 V	IO voltage under extended operating temperature	-0.3	3.7	V
Radio				
RF input level			10	dBm
RRAM memory				
Endurance		10,000		Write / rewrite cycles
Retention at 85 °C		10		y
Retention at 105 °C		2		y

	Note	Min.	Max.	Units
Environmental – QFN package types				
Storage temperature		-40	+125	°C
Reflow soldering temperature	Reflow cycle time is 30 seconds with 3 maximum reflow cycles		260	°C
Moisture Sensitivity Level (MSL)			2	
ESD Human Body Model (HBM)			1	KV
ESD Charged Device Model (CDM)			500	V
Environmental – CSP package types				
Storage temperature	Recommended storage condition is < 40 °C and < 90% RH (relative humidity)	-40	+125	°C
Reflow soldering temperature	Reflow cycle time is 30 seconds with 3 maximum reflow cycles.		260	°C
Moisture Sensitivity Level (MSL)			1	
ESD Human Body Model (HBM)			3	KV
ESD Charged Device Model (CDM)			250	V

9. Antenna

• AN54LQ Series

Antenna Gain and Efficiency

Test Result											
Frequency (MHz)	2400	2410	2420	2430	2440	2450	2460	2470	2480	2490	2500
Point Values											
Ant. Port Input Pwr. (dBm)	0.00	0.00	0.00	0.00	0.00	0.00	0.00	0.00	0.00	0.00	0.00
Tot. Rad. Pwr. (dBm)	-2.24	-2.22	-2.22	-2.25	-2.32	-2.46	-2.77	-3.02	-3.32	-3.52	-3.53
Peak EIRP (dBm)	1.30	1.25	1.15	1.22	1.35	1.42	1.31	1.20	1.00	1.03	1.23
Directivity (dBi)	3.54	3.47	3.38	3.47	3.67	3.88	4.08	4.22	4.32	4.55	4.76
Efficiency (dB)	-2.24	-2.22	-2.22	-2.25	-2.32	-2.46	-2.77	-3.02	-3.32	-3.52	-3.53
Efficiency (%)	59.75	60.00	59.94	59.59	58.68	56.74	52.79	49.91	46.60	44.42	44.32
Gain (dBi)	1.30	1.25	1.15	1.22	1.35	1.42	1.31	1.20	1.00	1.03	1.23
NHPRP $\pm\pi/4$ (dBm)	-3.94	-3.92	-3.93	-3.97	-4.05	-4.20	-4.54	-4.81	-5.15	-5.40	-5.45
NHPRP $\pm\pi/6$ (dBm)	-5.33	-5.29	-5.29	-5.32	-5.41	-5.56	-5.92	-6.20	-6.55	-6.83	-6.89
NHPRP $\pm\pi/8$ (dBm)	-6.33	-6.28	-6.28	-6.31	-6.40	-6.57	-6.93	-7.22	-7.59	-7.86	-7.93
Upper Hem. PRP (dBm)	-4.84	-4.83	-4.82	-4.84	-4.90	-5.04	-5.33	-5.55	-5.81	-5.99	-5.96
Lower Hem. PRP (dBm)	-5.69	-5.67	-5.69	-5.72	-5.79	-5.96	-6.29	-6.56	-6.91	-7.16	-7.22

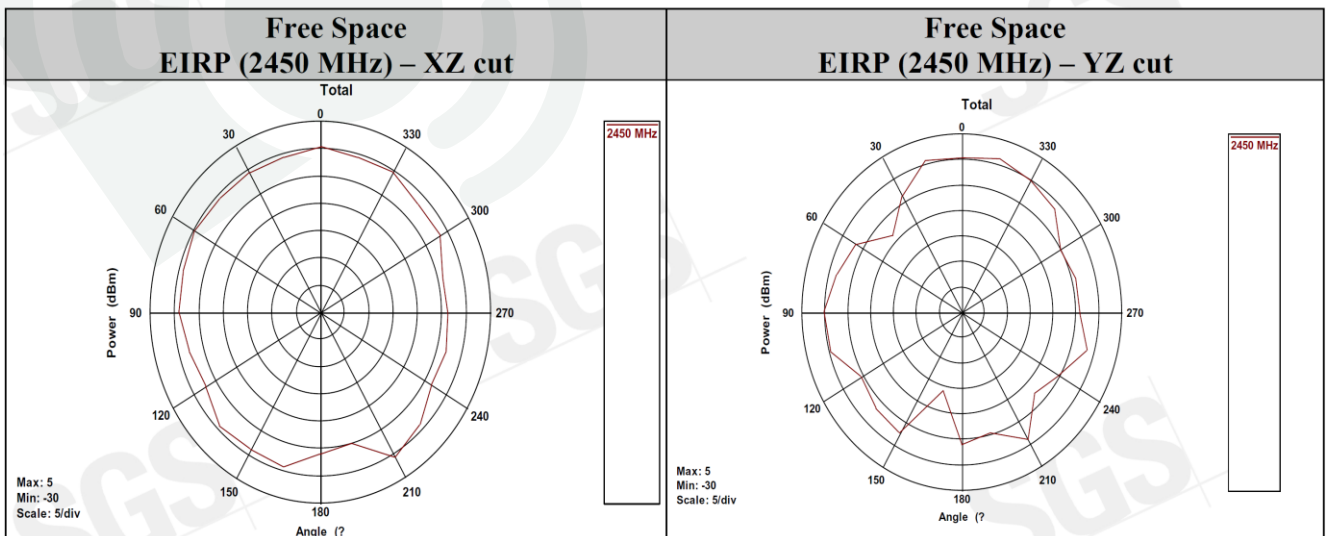
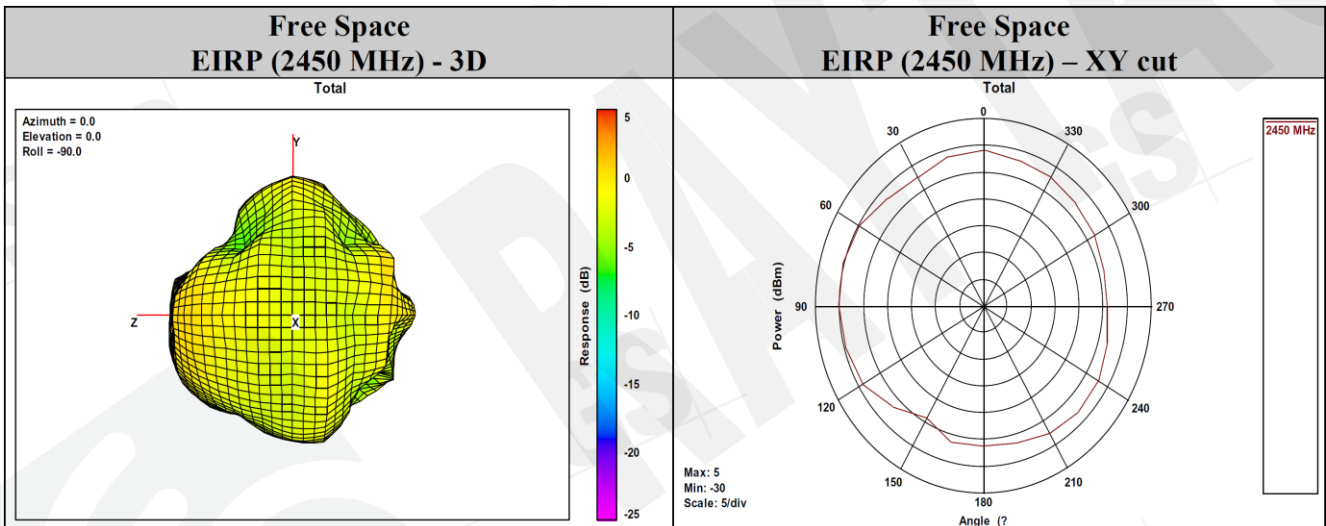

10. Reference circuit

Module is pre-programmed with Raytac's AT command firmware. Default is using "DC-DC mode". The firmware is set to use external 32.768kHz so please add it to make module work.

REMARK:

**** Please add X2 to make module work. ****

****Using the DC/DC regulator, the device checks if an inductor (L1) is connected to the DCC pin. If L1 is not detected, the device remains in LDO mode.****

**** DECD decoupling capacitor (2.2μF) is already inside the module. ****

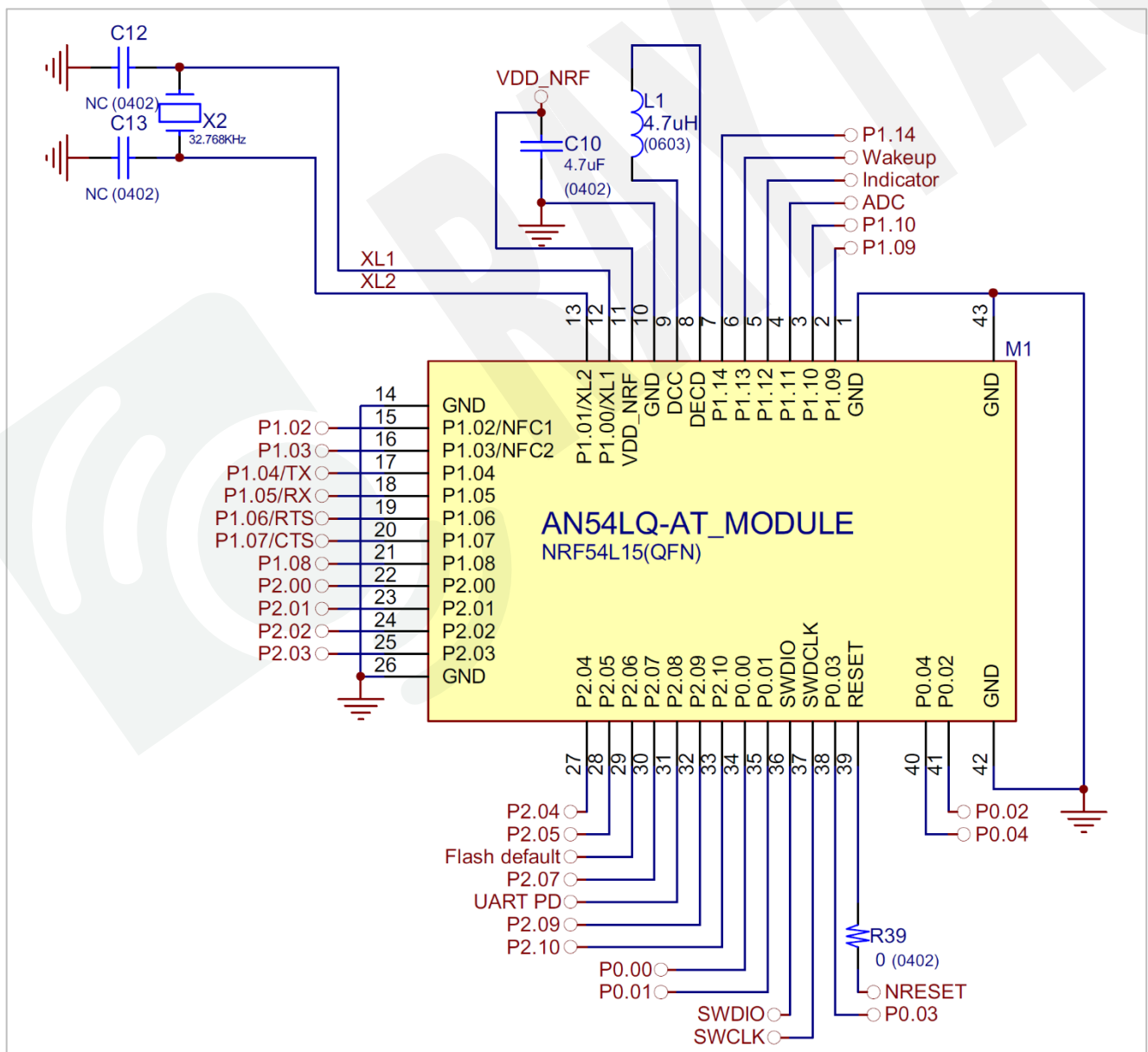

11. Certification

11.1. Declaration ID for Bluetooth

BT 6.0

Declaration ID	QDID(s) and Included DN(s)	Company	Specification Name
Q373526	Q360916 – Controller Subsystem Q361608 – Host Subsystem	Raytac Corporation	6.0

Profile Description	Service Description
Alert Notification Profile	Alert Notification Service
Blood Pressure Profile	Blood Pressure Service
	Device Information Service
Cycling Speed & Cadence Profile	Cycling Speed & Cadence Service
	Device Information Service
Glucose Profile	Glucose Service
	Device Information Service
Health Thermometer Profile	Health Thermometer Service
	Device Information Service
Heart Rate Profile	Heart Rate Service
	Device Information Service
HID over GATT Profile	HID Service
	Battery Service
Proximity Profile	Link Loss Service
	Immediate Alert Service
	TX Power Service
Running Speed & Cadence Profile	Running Speed & Cadence Service
	Device Information Service
Time Profile	Time Profile Service
Glucose Profile (Central)	
Mesh Profile	Mesh Provisioning Service
	Mesh Proxy Service

11.2. FCC Certificate (USA)

2.4GHz wireless module

				
TCB	TCB			
GRANT OF EQUIPMENT AUTHORIZATION Certification Issued Under the Authority of the Federal Communications Commission By:				
Raytac Corp. 8F, No.788-1, Zhongzheng Rd., Zhonghe Dist., New Taipei City,, 235 Taiwan	Kiwa Nederland B.V. Wilmersdorf 50 Apeldoorn, NL-7300 AC Netherlands			
Attention: Lyon Liu , President	Date of Grant: 07/30/2025 Application Dated: 07/23/2025			
NOT TRANSFERABLE EQUIPMENT AUTHORIZATION is hereby issued to the named GRANTEE, and is VALID ONLY for the equipment identified hereon for use under the Commission's Rules and Regulations listed below.				
FCC IDENTIFIER:	SH6AN54LQ			
Name of Grantee:	Raytac Corp.			
Equipment Class:	Digital Transmission System			
Notes:	Bluetooth Low Energy Module			
Modular Type:	Single Modular			
Grant Notes	FCC Rule Parts	Frequency Range (MHZ)	Output Watts	Frequency Emission Tolerance Designator
	15C	2402.0 - 2480.0	0.006	
<p>Power output listed is conducted. This grant is valid only when the module is sold to OEM integrators and must be installed by the OEM or OEM integrators. The antenna's as listed in this application must be installed to provide a separation distance of at least 20 cm from all persons and must not be co-located or operating in conjunction with any other antenna or transmitter. End-users may not be provided with the module installation instructions. OEM integrators and end-users must be provided with transmitter operating conditions for satisfying RF exposure compliance.</p>				
Certificate No.: 252181162/AA/00	Ron Scheepers Managing director			

SAR report



Report No.: TESA2502000154ES

Page: 1 of 9

RF EXPOSURE REPORT



Applicant: Raytac Corp.
8F, No.788-1, Zhongzheng Rd., Zhonghe Dist., New Taipei
City, 235, Taiwan

Manufacturer: Raytac Corp.
8F, No.788-1, Zhongzheng Rd., Zhonghe Dist., New Taipei
City, 235, Taiwan

Product Name: Bluetooth Low Energy Module

Brand Name: Raytac

Model No.: AN54LQ

Family Model No.: AN54LQ-P, AN54LQ-U

Model Difference: Dimensions, Antenna type

FCC ID SH6AN54LQ

IC: 8017A-AN54LQ

Date of EUT Received: Feb. 05, 2025

Issue Date: Jul. 21, 2025

Approved By _____

John Yeh
John Yeh

We hereby certify that:

The above equipment was evaluated by SGS Taiwan Ltd. The evaluation in this report is in compliance with FCC Rule Part §2.1091, KDB 447498 D01 v06 and RSS-102 issue 6.

The results of this report relate only to the sample identified in this report.

VERIFICATION OF COMPLIANCE

Issue Date: Jul. 11, 2025
Applicant: Raytac Corp.
Address: 8F, No.788-1, Zhongzheng Rd., Zhonghe Dist., New Taipei City, 235, Taiwan
Manufacturer: Raytac Corp.
Address: 8F, No.788-1, Zhongzheng Rd., Zhonghe Dist., New Taipei City, 235, Taiwan
Product: Bluetooth Low Energy Module
Brand Name/Trade Mark: Raytac
Model/Type: AN54LQ
Added Model(s): AN54LQ-P, AN54LQ-U
Applicable Standards: 47 CFR FCC Part 15 Subpart B
ICES-003 Issue 7 : October 2020
ANSI C63.4 : 2014
Test Laboratory: SGS Taiwan Ltd.
Electromagnetic Compatibility Laboratory
No.2, Keji 1st Rd., Guishan District, Taoyuan City, Taiwan
Test Report No.: TMHY2502000327YE, dated on Jul. 11, 2025

Conclusion: Based upon a review of the Test Report(s), the tested sample of the product mentioned above is deemed to comply with the requirements of the above standards.

Note: This verification is only valid for the product and configuration described and in conjunction with the test report as detailed above.

Authorised Signatory:



SGS Taiwan Ltd.
Eddy Cheng
Asst. Supervisor





11.3. TELEC Certificate (Japan)

1 Mbps & 2 Mbps

	
	Certificate of Radio Equipment in JAPAN 201-250520 / 00
	Issued 25 July 2025
	Page 1 of 5 This certificate has THREE Annexes
	<p>Kiwa Nederland B.V., operating as Japan Conformity Assessment Body (CAB ID Number: 201), according procedure RD_740, declares that the listed product complies with the Technical Regulations Conformity Certification of Specified Radio equipment (ordinance of MPT N° 37,1981)</p>
	Product description: Bluetooth Low Energy Module
	Trademark: Raytac
	Type designation: AN54LQ
	Hardware / Software: 1 / 1
	Variants: See Annex 3
Manufacturer: Raytac Corp.	
Address: 8F., No. 788-1, Zhongzheng Rd., Zhonghe Dist.,	
City: 235 New Taipei City	
Country: Taiwan	
This certificate is granted to:	
Name: Raytac Corp.	
Address: 8F., No. 788-1, Zhongzheng Rd., Zhonghe Dist.,	
City: 235 New Taipei City	
Country: Taiwan	
	
Ron Scheepers Managing director	
<p>Kiwa Nederland B.V. Wilmersdorf 50 Postbus 137 7300 AC Apeldoorn The Netherlands</p> <p>https://www.kiwa.com/nl/en/markets/ radio-wireless-and-electrical- equipment/</p> <p>Chamber of commerce 08090048</p> 	

11.4. NCC Certificate (Taiwan)

1 Mbps & 2 Mbps

	台灣檢驗科技股份有限公司 電信管制射頻器材型式認證證明	 Product Certification PC037
		證照字號：型式字第 AM 號
一、申請者：	勁達國際電子股份有限公司	
二、地址：	臺北市大安區和平東路 1 段 145 號 5 樓之 1	
三、製造廠商：	勁達國際電子股份有限公司	
四、器材名稱：	藍牙模組	
五、廠牌：	Raytac	
六、型號：	AN54LQ	
七、發射功率(電場強度)：	詳細射頻規格如備註欄	
八、工作頻率：	詳細射頻規格如備註欄	
九、審驗日期：	114年07月28日	
十、審驗合格標籤式樣：		
十一、警語或標示要求：	(器材本體、使用手冊、外包裝盒等應遵守下列標示要求)	
1.	應於本體明顯處標示審驗合格標籤或符合性聲明標籤及其型號，並於包裝盒標示主管機關標章。最終產品應於本體明顯處標示非隨插即用射頻模組(組件)之審驗合格標籤及最終產品型號，並於包裝盒標示主管機關標章，始得販賣。	
2.	依主管機關或相關技術規範規定於指定位置標示正體中文警語。	
3.	經授權使用射頻模組(組件)之審驗合格標籤者，應於最終產品說明書及包裝盒提供充分與正確之資訊。	
4.	於網際網路販賣電信管制射頻器材者，應於該網際網路網頁標示其型號及審驗合格標籤或符合性聲明標籤資訊。但最終產品得僅標示其型號及其組裝之非隨插即用射頻模組(組件)之審驗合格標籤資訊。	
5.	使用手冊應標示下列資訊：	
(1)	取得審驗證明之低功率射頻器材，非經核准，公司、商號或使用者均不得擅自變更頻率、加大功率或變更原設計之特性及功能。低功率射頻器材之使用不得影響飛航安全及干擾合法通信；經發現有干擾現象時，應立即停用，並改善至無干擾時方得繼續使用。前述合法通信，指依電信管理法規定作業之無線電通信。低功率射頻器材須忍受合法通信或工業、科學及醫療用電波輻射性電機設備之干擾。	
型式認證號碼：	CCAM25Y10170T6	
第 1 頁，共 2 頁		本證書與續頁分開使用無效

11.5. CE Test Report (EU)

1 Mbps & 2 Mbps

Report No.: TERF2502000649E2

Page: 1 of 62

AS/NZS 4268:2017 Amd 1:2021
ETSI EN 300 328 V2.2.2: 2019
TEST REPORT



Applicant: Raytac Corp.
8F, No.788-1, Zhongzheng Rd., Zhonghe Dist., New Taipei
City, 235, Taiwan

Manufacturer: Raytac Corp.
8F, No.788-1, Zhongzheng Rd., Zhonghe Dist., New Taipei
City, 235, Taiwan

Product Name: Bluetooth Low Energy Module

Brand Name: Raytac

Model No.: AN54LQ

Family Model No.: AN54LQ-P, AN54LQ-U

Model Difference: Dimensions, Antenna type

Report Number: TERF2502000649E2

Date of EUT Received: February 5, 2025

Date of Test: February 13, 2025~July 2, 2025

Issue Date: July 21, 2025

Approved By

Vito Pei

We hereby certify that:

The above equipment was tested by SGS Taiwan Ltd., Central RF Lab for compliance with the requirements set forth in the European Standard ETSI EN 300 328 V2.2.2: 2019 under 2014/53/EU and Australian/New Zealand Standard AS/NZS 4268:2017 Amd 1:2021, Row 59. The results of testing in this report apply to the product system that was tested only. Other similar equipment will not necessarily produce the same results due to production tolerance and measurement uncertainties.

RF EXPOSURE REPORT



Applicant: Raytac Corp.
8F, No.788-1, Zhongzheng Rd., Zhonghe Dist., New Taipei
City, 235, Taiwan

Manufacturer: Raytac Corp.
8F, No.788-1, Zhongzheng Rd., Zhonghe Dist., New Taipei
City, 235, Taiwan

Product Name: Bluetooth Low Energy Module

Brand Name: Raytac

Model No.: AN54LQ

Family Model No.: AN54LQ-P, AN54LQ-U

Model Difference: Dimensions, Antenna type

Date of EUT Received: Feb. 05, 2025

Issue Date: Jul. 21, 2025

Approved By _____



John Yeh
John Yeh

We hereby certify that:

The above equipment was evaluated by SGS Taiwan Ltd. for compliance with the requirements set forth in the European Standard EN 62479:2010, EN 50663: 2017 and Australia/New Zealand Standard AS/NZS 2772.2:2016.

The results in this report apply to this specific product system.

TEST REPORT IEC/EN 62368-1 Audio/video, information and communication technology equipment Part 1: Safety requirements	
Report Number.....	TSSF2502000091L0
Date of issue	2025-07-14
Total number of pages	50
Name of Testing Laboratory preparing the Report	SGS Taiwan Ltd. Safety Laboratory
Applicant's name	Raytac Corp.
Address	8F, No.788-1, Zhongzheng Rd., Zhonghe Dist., New Taipei City, 235, Taiwan
Test specification:	
Standard	IEC 62368-1:2018 and EN IEC 62368-1:2020+A11:2020
Test procedure	Commission testing
Non-standard test method	N/A
TRF template used	IECEE OD-2020-F1:2021, Ed.1.4
Test Report Form No.	IEC62368_1F modify by SGS TW (EN)
Test Report Form(s) Originator....	UL(US)
Master TRF	Dated 2023-08-17
Copyright © 2021 IEC System of Conformity Assessment Schemes for Electrotechnical Equipment and Components (IECEE System). All rights reserved. <small>This publication may be reproduced in whole or in part for non-commercial purposes as long as the IECEE is acknowledged as copyright owner and source of the material. IECEE takes no responsibility for and will not assume liability for damages resulting from the reader's interpretation of the reproduced material due to its placement and context.</small>	
General disclaimer:	
<small>The test results presented in this report relate only to the object tested. This report shall not be reproduced, except in full, without the written approval of the Issuing CB Testing Laboratory. The authenticity of this Test Report and its contents can be verified by contacting the NCB, responsible for this Test Report.</small>	

Test item description	Bluetooth Low Energy Module	
Trade Mark(s)	Raytac	
Manufacturer	Raytac Corp. 8F, No.788-1, Zhongzheng Rd., Zhonghe Dist., New Taipei City, 235, Taiwan	
Model/Type reference	AN54LQ, AN54LQ-P, AN54LQ-U	
Ratings	3.3Vdc	
Responsible Testing Laboratory (as applicable), testing procedure and testing location(s):		
<input type="checkbox"/> Testing Laboratory:	SGS Taiwan Ltd., Safety Laboratory	
Testing location/ address	No. 33, Wu Chyuan Road, New Taipei Industrial Park, Wu Ku District, New Taipei City 24886, Taiwan	
Tested by (name, function, signature)	Jeffrey Liang Project handler	
Approved by (name, function, signature) .. :	Kenny Cheng Reviewer	

VERIFICATION OF COMPLIANCE

Issue Date: Jul. 11, 2025
Applicant: Raytac Corp.
Address: 8F, No.788-1, Zhongzheng Rd., Zhonghe Dist., New Taipei City, 235, Taiwan
Manufacturer: Raytac Corp.
Address: 8F, No.788-1, Zhongzheng Rd., Zhonghe Dist., New Taipei City, 235, Taiwan
Product: Bluetooth Low Energy Module
Brand Name/Trade Mark: Raytac
Model/Type: AN54LQ
Added Model(s): AN54LQ-P, AN54LQ-U
Applicable Standards: EN 301 489 –1 v2.2.3 : 2019-11
EN 301 489 –17 v3.3.1 : 2024-09
EN 55032 : 2015+A11:2020
EN IEC 61000-3-2 : 2019+A1:2021
EN 61000-3-3 : 2013+A1:2019+A2:2021+AC:2022-01
EN 61000-4-2 : 2009
EN IEC 61000-4-3 : 2020
EN 61000-4-4 : 2012
EN 61000-4-6 : 2014+AC:2015
Test Laboratory: SGS Taiwan Ltd.
Electromagnetic Compatibility Laboratory
No.2, Keji 1st Rd., Guishan District, Taoyuan City, Taiwan
Test Report No.: TMHY2502000325YE, dated on Jul. 11, 2025

Conclusion: Based upon a review of the Test Report(s), the tested sample of the product mentioned above is deemed to comply with the requirements of the above standards.

Note: This verification is only valid for the product and configuration described and in conjunction with the test report as detailed above.

Authorised Signatory:



SGS Taiwan Ltd.
Eddy Cheng
Asst. Supervisor

RCM SDoc

Supplier's declaration of conformity



This is the Australian Communications and Media Authority (ACMA) approved form for a declaration of conformity under the following legislative instruments:

- > Radiocommunications Equipment (General) Rules 2021
- > Radiocommunications Labelling (Electromagnetic Compatibility) Notice 2017.

This is a sample form for a declaration of conformity under the Telecommunications (Labelling Notice for Customer Equipment and Customer Cabling) Instrument 2025.

Instructions for completion

Do not return this form to the ACMA. This completed form must be retained by the supplier as part of the documentation required for the compliance records. However, it must be made available for inspection by the ACMA when requested.

Supplier's details (manufacturer, importer or authorised agent)

Company name (or individual)

N121 PTY LTD

ACN/ARBN

646 997 373

Street address (Australia or New Zealand)

UNIT 5, 25-31 ALEXANDRA STREET
DRUMMOYNE NSW 2047, AUSTRALIA

Product details and date of manufacture

Product description – brand name, type, current model, lot, batch or serial number (if available), software/firmware version (if applicable)

Equipment name: Bluetooth Low Energy Module

Model name: AN54LQ

Variant model name: AN54LQ-P, AN54LQ-U

Brand name: Raytac

Compliance – applicable standards and other supporting documents

Evidence of compliance with applicable standards may be demonstrated by test reports, endorsed/accredited test reports, certification/competent body statements.

Having had regard to these documents, I am satisfied the above-mentioned product complies with the requirements of the relevant ACMA standards made under the *Radiocommunications Act 1992* and/or the *Telecommunications Act 1997*.

List these documents including details of the standard title, number and, if applicable, number of the test report/endorsed test report or certification/competent body statement.

Standard	Report number
Radiocommunications Labelling (Electromagnetic Compatibility) Notice 2017 (AS/NZS CISPR 32:2015+A1:2020)	TMHY2502000326YE
Radiocommunications Equipment (General) Rules 2021	TERF2508002564E2

Declaration

I hereby declare that:

1. I am authorised to make this declaration on behalf of the Company mentioned above
2. the contents of this form are true and correct
3. the product mentioned above complies with the applicable above mentioned standards and all products supplied under this declaration will be identical to the product identified above
4. I understand that giving false or misleading information is a serious offence.

Note: It is an offence to knowingly provide false or misleading information to a Commonwealth entity or a person who is exercising powers, performing functions under, or in connection with, a law of the Commonwealth. It is an offence to knowingly provide false or misleading information or documents in compliance or purported compliance with a law of the Commonwealth. (See sections 137.1 and 137.2 of the *Criminal Code Act 1995*.)

Penalty: 12 months imprisonment

Signature of Authorised Person	Date	Print Name	Position
	August 19, 2025	Daniel	Managing Director

The *Privacy Act 1988* (Cth) (the Privacy Act) imposes obligations on the ACMA in relation to the collection, security, quality, access, use and disclosure of personal information. These obligations are detailed in the Australian Privacy Principles.

The ACMA may only collect personal information if it is reasonably necessary for, or directly related to, one or more of the ACMA's functions or activities.

The purpose of collecting the personal information in this form is to ensure the supplier is identified in the 'declaration of conformity'. If this declaration of conformity is not completed and the requested information is not provided, a compliance label cannot be applied.

Further information on the Privacy Act and the ACMA's privacy policy is available at www.acma.gov.au/privacypolicy. The privacy policy contains details about how you may access personal information about you that is held by the ACMA, and seek the correction of such information. It also explains how you may complain about a breach of the Privacy Act and how we will deal with such a complaint.

Should you have any questions in this regard, please contact the ACMA's privacy contact officer on telephone on 1800 226 667 or by email at privacy@acma.gov.au.

Supplier's Declaration of Conformity

Section 134 (1) (g) of the New Zealand Radiocommunications Act 1989

Supplier's Details:

Name: JNM NZ LIMITED

Supplier Number: E9659

New Zealand Company Number: 8308895

Address: 1 Mariner Lane Beachlands2018 New Zealand

Product Details:

Brand name (Manufacture name)	Raytac		
Product name (Description)	Bluetooth Low Energy Module	Model name	AN54LQ
		Variant model	AN54LQ-P, AN54LQ-U
Frequency	2 402 MHz ~ 2 480 MHz	Radiated power e.i.r.p (dBm):	9.86 dBm
Applicable Standards Title, Number and Edition	AS/NZS CISPR 32:2015+A1:2020 AS/NZS 4268:2017:AMD1:2021 ETSI EN 300 328 V 2.2.2		
Test Report Numbers	TMHY2502000326YE TERF2508002564E2		

I hereby declare that the product to which this Declaration of conformity relates complies with the above-mentioned standard(s), and all products supplied under this Declaration will be identical to the sample identified in this Declaration.



Daniel
Director
05 August 2025

11.6. IC Certificate (Canada)

2.4GHz wireless module

 CERTIFICATE	CB	TECHNICAL ACCEPTANCE CERTIFICATE CERTIFICAT D'APPROBATION TECHNIQUE		
	▶ Reg. No. NL0001			
	CERTIFICATION No No. DE CERTIFICATION	8017A-AN54LQ		
	Issued	30 July 2025		
	Page	1 of 2 This certificate has ONE Annex		
	KIWA No. No. DE KIWA	252170402/AA/00		
	TEST SITE No. No. DE LABORATOIRE	4620E		
	ISSUED TO DÉLIVRÉ A	Raytac Corp. 8F, No.788-1, Zhongzheng Rd., Zhonghe Dist. New Taipei City 235 Taiwan		
	TYPE OF EQUIPMENT GENRE DE MATÉRIEL	Bluetooth device		
	TRADE NAME MARQUE	Raytac		
MODEL (HVIN) MODELE (HVIN)	AN54LQ, AN54LQ-P, AN54LQ-U			
FVIN	1			
PMN	AN54LQ, AN54LQ-P, AN54LQ-U			
CERTIFIED TO CERTIFIÉ SELON LE	SPECIFICATION CAHIER DES CHARGES	RSS-102 RSS-247	ISSUE EDITION	6 3
ISSUED BY KIWA NEDERLAND B.V. (NL0001), RECOGNIZED CERTIFICATION BODY BY INNOVATION, SCIENCE AND ECONOMIC DEVELOPMENT CANADA, ACCORDING THE CANADIAN CERTIFICATION BODY SCHEME (REC-CB). DÉLIVRÉ PAR KIWA NEDERLAND B.V. (NL0001), ORGANISME DE CERTIFICATION RECONNU PAR INNOVATION, SCIENCES ET DÉVELOPPEMENT ÉCONOMIQUE CANADA, SELON LE SYSTÈME D'ORGANISME DE CERTIFICATION DE CANADA (REC-CB).				
I hereby attest that the subject equipment was tested and found to be in compliance with the noted specification. J'atteste, par la présente, que le matériel a fait l'objet d'essai et a été jugé conforme à la spécification indiquée.				

<p>Kiwa Nederland B.V. Wilmersdorf 50 Postbus 137 7300 AC Apeldoorn The Netherlands</p> <p>https://www.kiwa.com/nl/en/markets/radio-wireless-and-electrical-equipment/</p> <p>Chamber of commerce 08090048</p>	 David Chen Reviewer	 George Chen Decision maker	
--	---	--	---

11.7. SRRC Certificate (China)

编号: 2025-17811
Certificate No.

无线电发射设备型号核准证

Radio Transmission Equipment Type Approval Certificate

劲达国际电子股份有限公司 (台湾):

根据《中华人民共和国无线电管理条例》, 经审查, 下列设备准予颁发无线电发射设备型号核准证。

In accordance with the Radio Regulations of the People's Republic of China, after examination, the Radio Transmission Equipment Type Approval Certificate is granted to the following equipment.

设备名称: 蓝牙模块
Equipment Name

设备型号: AN54LQ
Equipment Type

核准代码: 25J71R80L541
CMIIT ID

主要功能: 数据传输
Main Functions

有效期: 2030-04-03
Validity

其他事项载于附页。
Additional Items as Seen in Attachments.



Sealed by Issuing Authority

2025年 08月 15日

Year Month Date

中华人民共和国工业和信息化部统一制作

Issued by the Ministry of Industry and Information Technology of the People's Republic of China

11.8. KC Certificate

2.4GHz wireless module

038F-75EF-DD68-7C60

방송통신기자재등의 적합등록 필증 <i>Registration of Broadcasting and Communication Equipments</i>	
상호 또는 성명 Trade Name or Registrant	Raytac Corporation
기자재명칭(제품명칭) Equipment Name	Bluetooth Low Energy Module
기기부호/추가 기기부호 Equipment code /Additional Equipment code	LARN8
기본모델명 Basic Model Number	AN54LQ-U
파생모델명 Series Model Number	AN54LQ, AN54LQ-P
등록번호 Registration No.	R-R-ryt-AN54LQ
제조사/제조국가 Manufacturer/Country of Origin	Raytac Corporation/대만
등록연월일 Date of Registration	2025-07-28
기타 Others	<small> 기본모델명: AN54LQ-U External Antenna Dipole Antenna Type 1) 제조사: Aristelle 모델명: RFA-02-S-012K120000 안테나 이득(dBi): 5.4 2) 제조사: YAGEO 모델명: ANTX100FP11024003 안테나 이득(dBi): 3.3 3) 제조사: YAGEO 모델명: ANTX100FP11024003 안테나 이득(dBi): 2.2 4) 제조사: YAGEO 모델명: ANTX100ETAN02453 안테나 이득(dBi): 2.22 파생모델명: AN54LQ Internal Antenna Monopole antenna Type 1) 제조사: Raytac Corp. 안테나 이득(dBi): 1.42 파생모델명: AN54LQ-P Internal Antenna PIFA antenna Type 1) 제조사: Raytac Corp. 안테나 이득(dBi): 0.86 </small>
<p>위 기자재는 「전파법」 제58조의2 제3항에 따라 등록되었음을 증명합니다. It is verified that foregoing equipment has been registered under the Clause 3, Article 58-2 of Radio Waves Act.</p> <p style="text-align: right;">2025년(Year) 08월(Month) 07일(Day)</p> <p style="text-align: center;">국립전파연구원장</p> <p style="text-align: center;">  Director General of National Radio Research Agency </p> <p style="text-align: center; color: red;"> ※ 적합등록 방송통신기자재는 반드시 "적합성평가표시" 를 부착하여 유통하여야 합니다. 위반시 과태료 처분 및 등록이 취소될 수 있습니다. </p>	

11.9. WPC Certificate (India)



Government of India
Ministry of Communications
Department of Telecommunications
WPC Wing
Sanchar Bhawan, New Delhi-110001.

[Generation of Equipment Type Approval (ETA) through self-declaration issued under O.M. No. ETA-WPC /Policy/2018-19 dated 26 February, 2019].

THIS ETA IS ISSUED FOR A SINGLE MODEL WITH MODEL NAME AN54LQ (AN54LQ-P AN54LQ-U)

Registration No: ETA-SD-20250807326

Date: 01-09-2025

I). Details of Applicant and Parameters of Equipment:

1.	Name & Address of the first Applicant. (Indian Manufacturer/ Authorised Indian representative for foreign manufacturer)	ATOLL SOLUTIONS PRIVATE LIMITED, No. 143, First Floor, 10th Cross 1st Stage, Indiranagar Bangalore Bangalore, Bangalore Urban,KARNATAKA,560038
2.	Equipment category	Bluetooth module
3.	Make	Raytac Corporation,Taiwan
4.	Model	AN54LQ (AN54LQ-P AN54LQ-U)
5.	Frequency range(s) of Equipment	1. 2402-2480 MHz
6.	Max output power/Field strength/PSD	1. E.I.R.P. (Watts). 0.006

7.	Applicable Gazette Notification(s)	1. 1047 (E) Dated 18-10-2018	
8.	RF Test Report details:-		
	Name&Address /Country of accredited laboratory issuing the RF test report	Accreditation Certificate Reference/Number	Test Report No. and Date
	SGS Taiwan Ltd & No134, Wu Kung Road,New Taipei Industrial Park, Wuku District, New Taipei City, Taiwan	252181162/AA/00	TERF2502000650E2 & 18-07-2025

II). Terms and Conditions

- (i). This certificate will not be valid in case any change in the above parameters and not conforming to the Gazette Notification mentioned in sl.no 7 above.
- (ii). Use of such equipment has been exempted from licensing requirement vide Gazette Notification mentioned in sl. no. 7, on Non-interference,Non-protectionand sharing (non-exclusive) basis.
- (iii). Use of such equipment in case not conforming to above notification will require a specific wireless operating license, as applicable from this Ministry.
- (iv). Field units of WPC Wing reserve the right for sample check/audit carried out for the purpose of RF analysis/spectrum monitoring in view to avoid interference to other wireless users and ensure compliance of technical parameters mentioned in sl no. 5,6&7.
- (v). This certificate is valid only for equipment which are exempted from import licensing requirements as per the Import Policy of DGFT and for import of such device, a self-declaration based, system generated (Saralsanchar) Import undertaking/ permission is required.
- (vi). The applicant is liable for prosecution under Indian Law in case of any wrong declaration/ submission of ingenuine RF test report(s) for issue of ETA through Self-Declaration.

Note:

1. Once ETA through self-declaration is generated for a model, subsequently it may be utilized by other person(s) for import/usage purpose in India.
2. The importers of above model shall comply with other import related requirements, if any, with Customs.

This is Self-generated certificate. Hence, no signature is required. It may be downloaded/verified from the website <https://saralsanchar.gov.in>.

11.10. EU and UKCA Declarations of Conformity

The product complies with the applicable requirements of both the European Union and United Kingdom regulations, including the essential requirements of the following directives:

- **Radio Equipment Directive: 2014/53/EU**
- **RoHS Directive: 2011/65/EU Annex II and its amendment Directive (EU) 2015/863**

Conformity is demonstrated with reference to the following harmonized standards, based on test reports issued by SGS Taiwan Ltd.:

- **EN 300 328 V2.2.2:2019**
- **EN 301 489-1 V2.2.3 : 2019-11**
- **EN 301 489-17 V3.3.1 : 2024-09**
- **EN 55032 : 2015+A11:2020**
- **EN 61000-4-2 : 2009**
- **EN IEC 61000-4-3 : 2020**
- **EN 61000-4-4 : 2012**
- **EN 61000-4-6 : 2014+AC:2015**
- **IEC 62368-1 : 2018 and BS EN IEC 62368-1 : 2020+A11:2020**

RoHS compliance reports were issued by TÜV Rheinland Hong Kong Ltd., covering Directive 2011/65/EU and its amendment Directive (EU) 2015/863.

11.11. RoHS & REACH Report

Please visit "[Support](#)" page of our website to download.

11.12. End-Product Label

It is suggested using following content adding to package or user manual or label to obey the regulation. Any rules of end-product label shall refer to each certification for final reference.

11.12.1. FCC (USA)

The FCC statement should be included in the user manual when there is no enough space on label. Otherwise, it should be included on the label.

“This device complies with part 15 of the FCC rules. Operation is subject to the following two conditions. (1) This device may not cause harmful interference. (2) This device must accept any interference received, including interference that may cause undesired operation.”

The final end product must be labeled in a visible area with the following: **“Contain FCC ID: SH6AN54LQ”**.

11.12.2. TELEC (Japan)

When manufacturer is placing the product on the Japanese market, the product must be affixed with the following Specified Radio Equipment marking:



11.12.3. NCC (Taiwan)

根據 NCC LP0002 低功率射頻器材技術規範_章節 3.8.2：

- 取得審驗證明之低功率射頻器材，非經核准，公司、商號或使用者均不得擅自變更模組之頻率、加大功率或更改原設計之特性與功能。
- 低功率射頻器材之使用不得影響飛航安全及干擾合法通信；經發現有干擾現象時，應立即停用，並改善至無干擾時方得繼續使用。
- 低功率射頻器材須忍受合法通信或工業、科學及醫療用電波輻射性電機設備之干擾。

前述合法通信，係指依《電信管理法》規定作業之無線電通信。

此模組於取得認證後，將依規定於模組本體標示審驗合格標籤，並要求平台廠商於平台上標示。

請依下列標籤式樣自製標籤，標貼或印鑄於器材本體明顯處，始得販賣或公開陳列。

AN54LQ Series

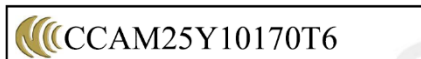

以 AN54LQ-15 為例，平台廠商必須於平台上標示字樣「本產品內含射頻模組：ID 編號 CCAM25Y10170T6」。

「平台」定義如下：若器材組裝本案模組，消費者仍能正常使用該器材主要功能，該器材得視為平台。若器材不組裝本案模組，消費者不能正常使用該器材主要功能，該器材不能視為平台。

該類不同廠牌型號器材組裝本案審驗模組後，須分別申請型式認證。

11.12.4. IC (Canada)

The IC statement should be included in the user manual when there is no enough space on label. Otherwise, it should be included on the label.

You are cautioned that changes or modifications not expressly approved by the party responsible for compliance could void the user's authority to operate the equipment.

This device contains licence-exempt transmitter(s)/receiver(s) that comply with Innovation, Science and Economic Development Canada's licence-exempt RSS(s). Operation is subject to the following two conditions:

1. This device may not cause interference, and
2. This device must accept any interference, including interference that may cause undesired operation of the device.

L'émetteur/récepteur exempt de licence contenu dans le présent appareil est conforme aux CNR d'Innovation, Sciences et Développement économique Canada applicables aux appareils radio exempts de licence. L'exploitation est autorisée aux deux conditions suivantes :

1. l'appareil ne doit pas produire de brouillage, et
2. l'utilisateur de l'appareil doit accepter tout brouillage radioélectrique subi, même si le brouillage est susceptible d'en compromettre le fonctionnement.

The final end product must be labeled in a visible area with the following: **“Contain IC ID: 8017A-AN54LQ”**.

11.13. Compliance and Certification

11.13.1. List of Applicable FCC Rules

This module has been tested and found to comply with the following requirements for Modular Approval.

- 47 CFR Part 15 Subpart C Intentional Radiators.

11.13.2. RF Exposure Considerations

This module has been evaluated for portable RF exposure conditions and is compliant with FCC RF exposure requirements when used in portable configurations. The module is approved for use without a minimum separation distance from the user's body.

Host product manufacturers integrating this module must ensure that their final host product maintains the portable use conditions as tested and documented in the RF exposure compliance reports referenced in the RF exposure exhibit.

Configuration with multiple transmitters in the same host, routine evaluation or SAR testing for the simultaneous transmission of the co-located transmitters according to KDB 447498 is required. The portable host product shall be evaluated for ensuring to continue compliance FCC rule part 2.1093 & part 1.1310 by C2PC. The additional guidance for the portable host products is provided in KDB Publication 996369 D02 and D04.

For the host product is not installed according to this guide, the module certification will be invalid, and a new grant certification will be required for the host product.

End-user documentation shall include the RF exposure information provided below.

RF Exposure Statement:

This equipment complies with FCC radiation exposure limits set forth for an uncontrolled environment. This transmitter must not be co-located or operating in conjunction with any other antenna or transmitter. The device has been evaluated for portable operation without separation distance from the user and meets the FCC RF exposure requirements for such use.

11.13.3. Antennas

This radio transmitter has been approved by Federal Communications Commission and Innovation, Science and Economic Development Canada to operate with the antenna types listed below, with the maximum permissible gain indicated. Antenna types not included in this list that have a gain greater than the maximum gain indicated for any type listed are strictly prohibited for use with this device.

Cet émetteur radio a été approuvé par la Commission fédérale des communications et Innovation, Sciences et Développement économique Canada pour fonctionner avec les types d'antennes énumérés ci-dessous, avec le gain maximal autorisé indiqué. Les types d'antennes non mentionnés dans cette liste dont le gain est supérieur au gain maximal indiqué pour l'un des types énumérés sont strictement interdits avec cet appareil.

On board antenna

Antenna Type	Supplier	Antenna Part No.	Freq. (MHz)	Peak Antenna Gain (dBi)
Monopole	Raytac	AN54LQ	2400~2500	1.42
PIFA	Raytac	AN54LQ-P	2400~2500	0.06

External antenna

Antenna Type	Supplier	Antenna Part No.	Freq. (MHz)	Peak Antenna Gain (dBi)
Dipole	Aristotle	RFA-02-5-F17H170100B	2400~2500	5
Dipole	YAGEO	ANTX100P111B24003	2400~2500	3.3
Dipole	YAGEO	ANTX100P011B24003	2400~2500	2.2
Dipole	Pulse	ANTX100ETHAB24553	2400~2500	2.22

11.13.4. Information on Test Modes and Additional Testing Requirements

The module can be configured to continuously transmit on a specific frequency with a fixed modulation pattern. This allows evaluation of radiated emissions and spurious emissions in a controlled condition.

These test modes are intended for compliance testing only and must not be enabled during normal operation of the final product.

For more detailed information, please contact the grantee for assistance with test modes needed for module/host compliance test requirements.

11.13.5. Additional Testing, Part 15 Subpart B Disclaimer

The modular transmitter is only FCC authorized for the specific rule parts (i.e., FCC transmitter rules) listed on the grant, and that the host product manufacturer is responsible for compliance to any other FCC rules that apply to the host not covered by the modular transmitter grant of certification.

The final host product still requires Part 15 Subpart B compliance testing with the modular transmitter installed.

11.13.6. Note EMI Considerations

Note that a host manufacture is recommended to use KDB996369 D04 Module Integration Guide recommending as "best practice" RF design engineering testing and evaluation in case non-linear interactions generate additional non-compliant limits due to module placement to host components or properties.

For standalone mode, reference the guidance in KDB996369 D04 Module Integration Guide and for simultaneous mode; see KDB996369 D02 Module Q&A Question 12, which permits the host manufacturer to confirm compliance.

11.13.7. How to Make Changes

You are cautioned that changes or modifications not expressly approved by the party responsible for compliance could void the user's authority to operate the equipment.

Only Grantees are permitted to make permissive changes, if the module will be used differently than granted conditions, please contact us to ensure modifications will not affect compliance.

12. Notes and Cautions

To ensure proper integration and long-term reliability of this RF module, the following regulatory and technical considerations must be observed:

The OEM integrator must not provide instructions to the end user regarding how to install or remove this RF module in the user manual of the final product that integrates this module.

The end user manual shall include all required regulatory information and warnings as shown in the official user manual.

This module is not designed for lifetime use. Like general electronic products, it may degrade after continuous usage over the years. To ensure optimal performance and longevity, please observe the following precautions:

- Follow the guidelines of this document while designing circuit/end-product. Any discrepancy of core Bluetooth technology and technical specification of IC should refer to definition of Bluetooth Organization and Nordic Semiconductor as final reference.
- Do not supply voltage that is not within range of specification.
- Eliminate static electricity at any cost when working with the module as it may cause damage. It is highly recommended adding anti-ESD components to circuit design to prevent damage from real-life ESD events. Anti-ESD methods can be also applied in mechanical design.
- Do not expose modules under direct sunlight for long duration. Modules should be kept away from humid and salty air conditions, and any corrosive gasses or substances. Store it within -40°C to $+125^{\circ}\text{C}$ before and after installation.
- Avoid any physical shock, intense stress to the module or its surface.
- Do not wash the module. No-Clean Paste is used in production. Washing it will oxidize the metal shield and have chemistry reaction with No-Clean Paste. Functions of the module are not guaranteed if it has been washed.

The module is not suitable for life support device or system and not allowed to be used in destructive device or systems in any direct or indirect ways. The customer agrees to indemnify Raytac for any losses when applying modules in applications such as the ones described above.

13. Useful Links

- **Nordic Infocenter:** <https://infocenter.nordicsemi.com/index.jsp>
All the necessary technical files and software development kits of Nordic's chip are on this website.
- **Nordic Developer Zone:** <https://devzone.nordicsemi.com/questions/>
A highly recommended website for firmware developer. Interact with other developers and Nordic's employees will help with your questions. The site also includes tutorials in detail to help you get started.
- **Official Page of nRF54L15 :** <https://www.nordicsemi.com/Products/nRF54L15>
A brief introduction to nRF54L15 and download links for Nordic's developing software and SoftDevices.



History of Firmware Revision

FW Ver.	Compatible HW Build	Release Date	Description of Revision	Note
1.0		2026/05/21	1 st release.	

Full list of Raytac's Wi-Fi modules

● AN7002Q series (QFN package IC)

Series	Nordic Solution	Raytac No.	IC Ver.	Antenna	Size	Weight
AN7002Q	nRF7002	AN7002Q	1	Chip Antenna	17.1 x 10.8 x 2.1 mm	0.78 (±0.02g)
		AN7002Q-P	1	PCB Antenna	17.1 x 10.8 x 2.1 mm	0.79 (±0.02g)
		AN7002Q-U	1	u.FL Connector	16.4 x 10.8 x 2.1 mm	0.85 (±0.02g)



RAYTAC

Full list of Raytac's Bluetooth modules

● AN54LQ series (QFN package IC)

Series	Nordic Solution	Raytac No.	IC Ver.	Antenna	RAM	NVM
AN54LQ	nRF54L15	AN54LQ-15	1	Chip Antenna	256 kB	1524 KB
	nRF54L10	AN54LQ-10	1		192 kB	1012 KB
	nRF54L05	AN54LQ-05	1		96 kB	500 KB
AN54LQ-P	nRF54L15	AN54LQ-P15	1	PCB Antenna	256 kB	1524 KB
	nRF54L10	AN54LQ-P10	1		192 kB	1012 KB
	nRF54L05	AN54LQ-P05	1		96 kB	500 KB
AN54LQ-U	nRF54L15	AN54LQ-U15	1	u.FL Connector	256 kB	1524 KB
	nRF54L10	AN54LQ-U10	1		192 kB	1012 KB
	nRF54L05	AN54LQ-U05	1		96 kB	500 KB

● AN54LV series (WLCSP package IC)

Series	Nordic Solution	Raytac No.	IC Ver.	Antenna	RAM	NVM
AN54LV	nRF54L15	AN54LV-15	1	Chip Antenna	256 kB	1524 KB
AN54LV-P		AN54LV-P15	1	PCB Antenna		
AN54LV-U		AN54LV-U15	1	u.FL Connector		
AN54LV-K		AN54LV-K15	1	Pin Antenna		

● **MDBT53 series (WLCSP package IC)**

Series	Nordic Solution	Raytac No.	IC Ver.	Antenna	RAM	Flash Memory
MDBT53	nRF5340	MDBT53-1M	1	Chip Antenna	512 kB	1 MB
MDBT53-P	nRF5340	MDBT53-P1M	1	PCB Antenna	512 kB	1 MB
MDBT53-U	nRF5340	MDBT53-U1M	1	u.FL Connector	512 kB	1 MB

● **MDBT53V series (WLCSP package IC)**

Series	Nordic Solution	Raytac No.	IC Ver.	Antenna	RAM	Flash Memory
MDBT53V	nRF5340	MDBT53V-1M	1	Chip Antenna	512 kB	1 MB
MDBT53V-P	nRF5340	MDBT53V-P1M	1	PCB Antenna	512 kB	1 MB

● MDBT50 series (QFN package IC)

Series	Nordic Solution	Raytac No.	IC Ver.	Antenna	RAM	Flash Memory
MDBT50	nRF52820	MDBT50-256R	1	Chip Antenna	32 kB	256 kB
	nRF52833	MDBT50-512K	1		128 kB	512 kB
MDBT50-P	nRF52820	MDBT50-P256R	1	PCB Antenna	32 kB	256 kB
	nRF52833	MDBT50-P512K	1		128 kB	512 kB

● MDBT50Q series (aQFN package IC)

Series	Nordic Solution	Raytac No.	IC Ver.	Antenna	RAM	Flash Memory
MDBT50Q	nRF52840	MDBT50Q-1MEN	3	Chip Antenna	256 kB	1 MB
	nRF52840	MDBT50Q-1MV2	2			
	nRF52833	MDBT50Q-512K	1		128 kB	512 kB
MDBT50Q-P	nRF52840	MDBT50Q-P1MEN	3	PCB Antenna	256 kB	1 MB
	nRF52840	MDBT50Q-P1MV2	2			
	nRF52833	MDBT50Q-P512K	1		128 kB	512 kB
MDBT50Q-U	nRF52840	MDBT50Q-U1MEN	3	u.FL Connector	256 kB	1 MB
	nRF52840	MDBT50Q-U1MV2	2			
	nRF52833	MDBT50Q-U512K	1		128 kB	512 kB
Dongle	nRF52840	MDBT50Q-RX	1, 2	PCB Antenna	256 kB	1 MB
		MDBT50Q-CX-40	1			
	nRF52833	MDBT50Q-CX-33	1		128 kB	512 kB

● **MDBT42T series (WLCSP package IC)**

Series	Nordic Solution	Raytac No.	IC Ver.	Antenna	RAM	Flash Memory
MDBT42T	nRF52805	MDBT42T-192K	1	Chip Antenna	24 kB	192 kB
MDBT42T-P		MDBT42T-P192K		PCB Antenna		

● **MDBT42TV series (WLCSP package IC)**

Series	Nordic Solution	Raytac No.	IC Ver.	Antenna	RAM	Flash Memory
MDBT42TV	nRF52805	MDBT42TV-192K	1	Chip Antenna	24 kB	192 kB
MDBT42TV-P		MDBT42TV-P192K		PCB Antenna		

● **MDBT42 series (WLCSP package IC)**

Series	Nordic Solution	Raytac No.	IC Ver.	Antenna	RAM	Flash Memory
MDBT42	nRF52832	MDBT42-512KV2	2	Chip Antenna	64 kB	512 kB
MDBT42-P		MDBT42-P512KV2		PCB Antenna		

● **MDBT42V series (WLCSP package IC)**

Series	Nordic Solution	Raytac No.	IC Ver.	Antenna	RAM	Flash Memory
MDBT42V	nRF52832	MDBT42V-512KV2	2	Chip Antenna	64 kB	512 kB
MDBT42V-P		MDBT42V-P512KV2		PCB Antenna		

● MDBT42Q series (QFN package IC)

Series	Nordic Solution	Raytac No.	IC Ver.	Antenna	RAM	Flash Memory
MDBT42Q	nRF52832	MDBT42Q-512KEN	3	Chip Antenna	64 kB	512 kB
	nRF52832	MDBT42Q-512KV2	2			
	nRF52810	MDBT42Q-192KV2	2		24 kB	192 kB
	nRF52811	MDBT42Q-192KL	1			
MDBT42Q-P	nRF52832	MDBT42Q-P512KEN	3	PCB Antenna	64 kB	512 kB
	nRF52832	MDBT42Q-P512KV2	2			
	nRF52810	MDBT42Q-P192KV2	2		24 kB	192 kB
	nRF52811	MDBT42Q-P192KL	1			
MDBT42Q-U	nRF52832	MDBT42Q-U512KEN	3	u.FL Connector	64 kB	512 kB
	nRF52832	MDBT42Q-U512KV2	2			

● MDBT40 series

Series	Nordic Solution	Raytac No.	IC Ver.	Antenna	RAM	Flash Memory
MDBT40	nRF51822	MDBT40-256V3	3	Chip Antenna	16 kB	256 kB
		MDBT40-256RV3			32 kB	256 kB
MDBT40-P	nRF51822	MDBT40-P256V3	3	PCB Antenna	16 kB	256 kB
		MDBT40-P256RV3			32 kB	256 kB

Release Note

- 2026/06/12 Version 0.9: Preliminary.

